

Figure 2-11. Dummy Loads

2-353. The AC line voltage is applied to J3-1 and J3-4. When the J3-1 side is positive referenced to J3-4, the ac current flows, charging capacitors, as shown by the solid arrows in Figures 2-12A and 2-12B.

2-354. When J3-4 is positive referenced to J3-1, the AC current flows as shown by the dotted lines in Figures 2-12A and 2-12B.

2-355. Diode CR2 absorbs voltage transients on the AC line and protects other components from overstress or damage. E101 is connected across the AC line when the line voltage selector is set to 115V position. This circuit assures positive fuse blowing if the instrument is accidentally connected to 230V AC line power. Components L1, L2, R3, R4, R5 and C5 form a filter that reduces conducted emissions.

#### 2-356. A5A1 POWER SUPPLY PCB CIRCUIT ANALYSIS

2-357. The DC voltage at J1-1, J1-3, and J1-6 is applied to transistors Q1 and Q2 on the A5A1 PCB through a common mode noise filter which consists of capacitors C1, C2, and C3, and inductor L1. The voltage waveform between test point TP3 and the collector of switching transistor Q2 is depicted in Figure 2-13.

2-358. Refer to Figure 2-13. At time t1, transistor Q1 is turned on, connecting transformer T3 across capacitor C4. At time t2, Q1 is turned off and no voltage is applied to T3. At time t3, Q2 is turned on, connecting T3 across

capacitor C5. At time t4, transistor Q2 is turned off, removing VC5 from transformer T3.

2-359. Refer to Figure 2-14, Output Circuit of Switching Transistors Q1 and Q2. Capacitor C6 is a DC blocking capacitor which will prevent transformer T3 from becoming saturated when an unbalance of turn-on time exists in switching transistors Q1 and Q2. Transformer T4 is a current sense transformer which monitors the primary current of transformer T3. The output of transformer T4 is full-wave rectified by diodes CR6 and CR15, and is sent to the overload protection circuit on A5A2 Regulator PCB. A static shield is provided for Q1 and Q2 in order to reduce conducted emission to the chassis.

2-360. Figure 2-15 illustrates turn-off waveforms to the switching power transistor Q1. At time t0, the pulse width modulator is disabled, and no signal appears at the secondary side of transformer T1. At time t1, the pulsewidth modulator output ( $= V_{in}$ ) goes down to approximately zero volts. At this time the base voltage of Q1 becomes positive in respect to the emitter drawing base-emitter current. This turns on Q1. At the same time, current flows through C8, CR2, and R6, charging C8. At t2, the pulse width modulator output, which is an open collector, turns off letting  $V_{in}$  swing up to approximately twice +12 Volts. This will turn off Q1; however, due to the stored charge in C8, turn off time is relatively slow. This means Q1 will consume some power during the falltime. In order to reduce the power loss, Q3, C8, R5, and CR2 are provided. The moment the pulse width modulator

switch is off at  $t_2$ , the base of Q3 becomes positively biased, discharging the stored charge at the base of Q1. (Indicated by IB2 in Figure 2-15). If Q1 fails, shorting its collector to base and opening the emitter, diodes CR16, CR17, and CR18, provides protection for the components placed across the base/emitter circuit of Q1.

2-361. The voltage waveform shown in Figure 2-16 appears at the secondary side of transformer T3 and is full-wave rectified by CR7 through CR14. The LC filters, L3/C12, L5/C15, L7/C16, L8/C17 suppress ripple.

Inductors L4, L6, and L9 are common mode noise chokes. The RC networks, R23/C22, R24/C23, R17/C19 and R18/C10 are snubbers which reduce voltage spikes across the full-wave rectifiers. Rectifier diodes CR7 through CR12, and CR14 are chassis mounted. The pulse width modulator regulation signal is taken from the output of the +6V DC rectifier and is sent to the A5A2 Regulator PCB via J6 pin 1. The +6V, ±13V, and +25V outputs are available at J7 and pass through feed-through capacitors to the A5A6 Power Supply Capacitor PCB located under the cover on the rear of the instrument between the heat sink and the fan.

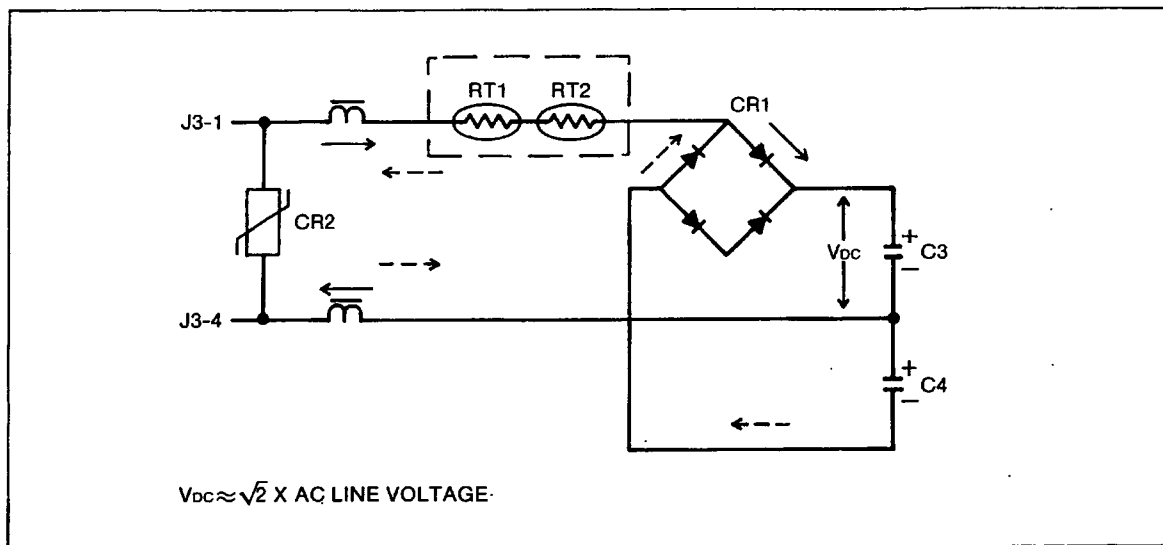

Figure 2-12A. AC Line Voltage Selector Set to 115V

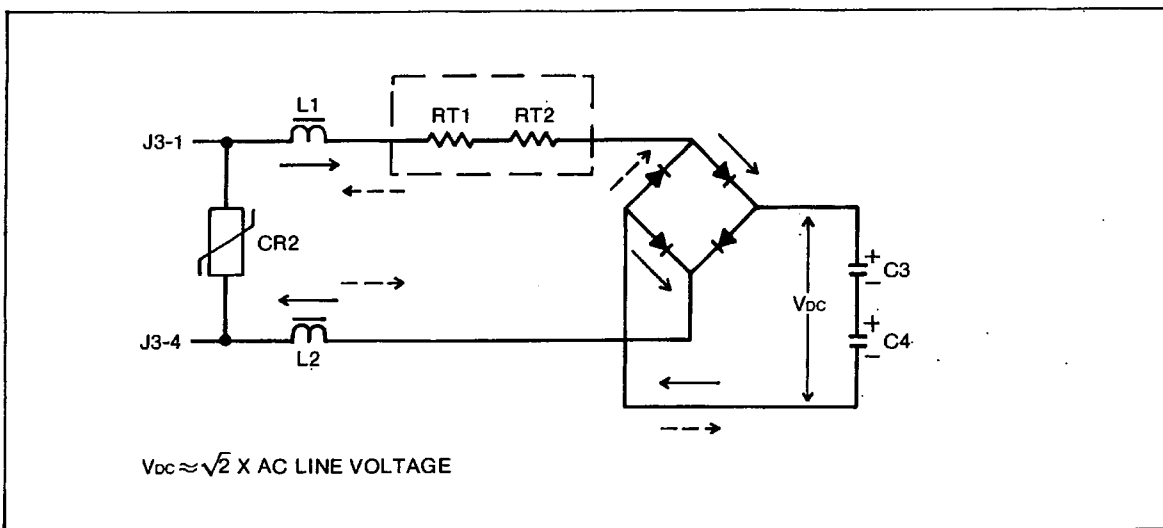

Figure 2-12B. AC Line Voltage Selector Set to 230V

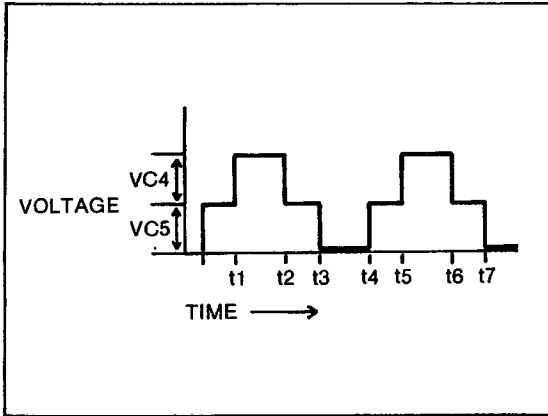

Figure 2-13. Voltage Waveform Between TP3 and Collector of Q2

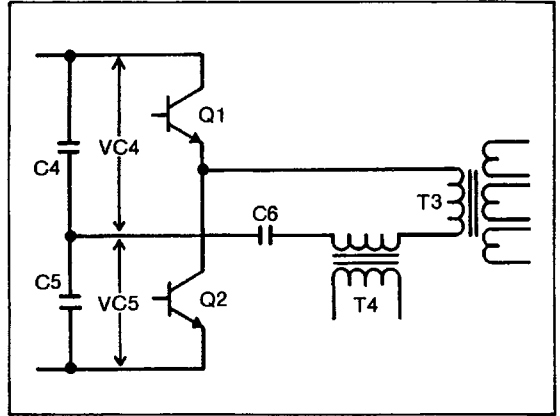

Figure 2-14. Output Circuit of Switching Transistors Q1 and Q2

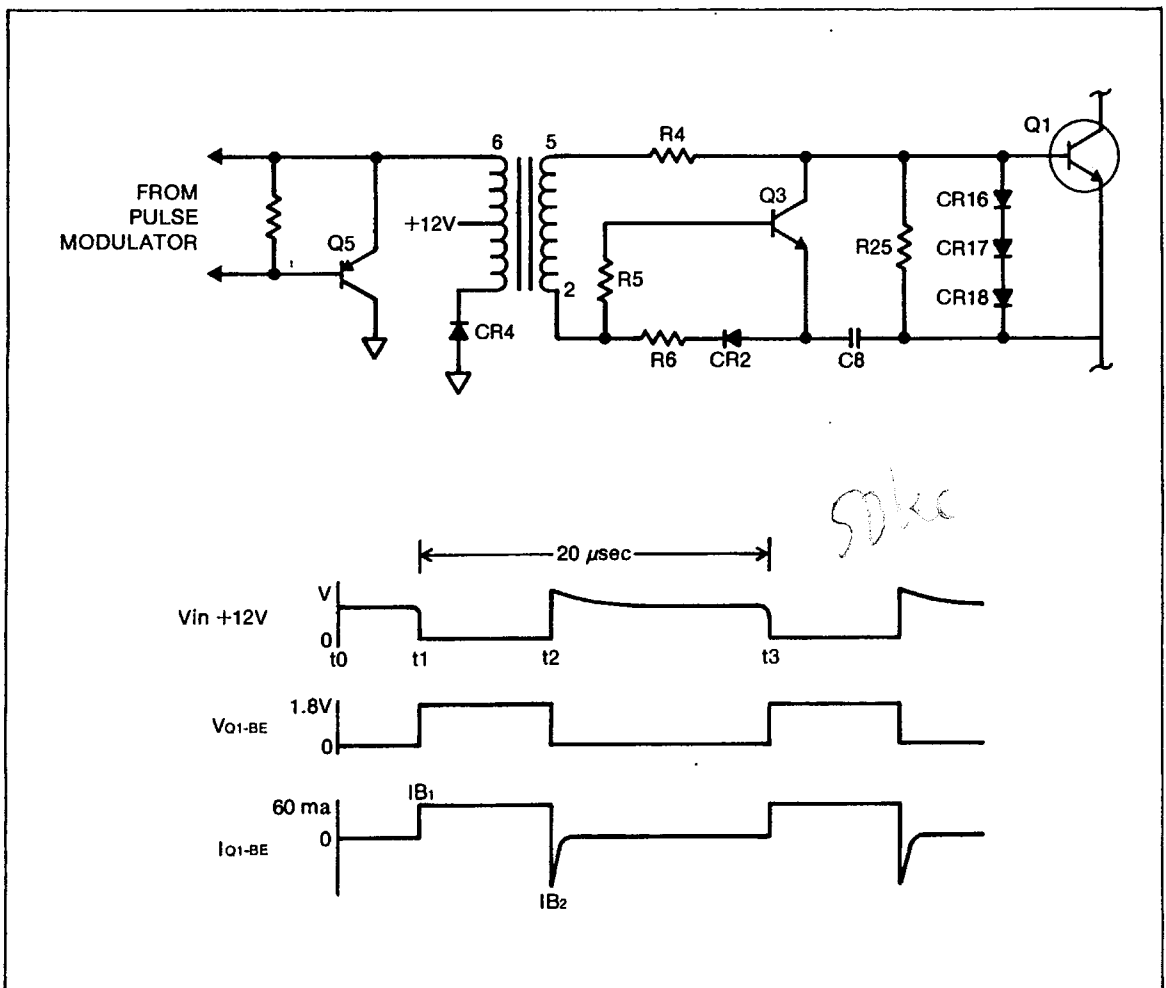

Figure 2-15. Switching Power Transistor Waveforms

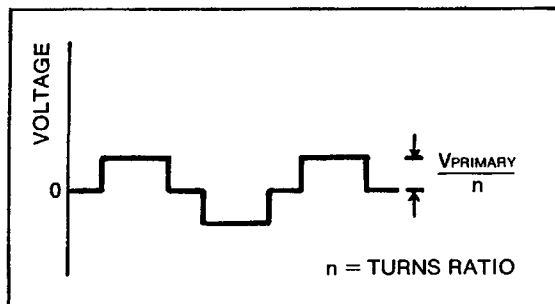

Figure 2-16. Voltage Waveform, Secondary of Transformer T3

### 2-362. A5A2 REGULATOR PCB CIRCUIT ANALYSIS

2-363. Refer to the Power Supply Schematic in the Schematic Manual. The +6V pwm regulation signal from the A5A1 PCB enters at E6. Inductors L2 through L6 and capacitors C9 through C13 form a ripple rejection filter. The signal is applied to the error amplifier U2 through a filter network. The reference voltage applied to the minus side of error amplifier U2 is set by R7 which adjusts the output voltage of the +6V DC switching power supply line. The output of error amplifier U2 controls the pulse width of pulse width modulator U1. When the voltage of the +6V DC line goes higher, the output at U2-6 follows, causing the pulse width at U1 pin-13 and U1 pin-11 to be narrower. This causes the voltage waveform at T3 on the A5A1 Power Supply to be narrower, resulting in lower DC output, thus regulating the output voltage. Potentiometer R1 (with Capacitor C4) determines the frequency of switching signal U1 pins-11 and -13 and is normally set to 20  $\mu$ s or 50 kHz. A reference voltage is provided to pulse width modulator U1 pin 7 to maintain dead time. The dead time prevents the switching transistors (Q1, Q2 on A5A5) from conducting simultaneously, thereby preventing the transistors from being damaged.

2-364. Components Q1, Q2, U3, and U4 form an overload protection circuit. The output of the current sense transformer T4 on the A5A1 Power Supply PCB is present at J4-6. This level is monitored by voltage comparator U4. If the voltage level at U4 pin 2 exceeds +3.33 volts (nominal), the voltage at U4 pin-7 goes up toward +12V DC bringing up pulse width modulator U1 pin-6. At the same time, one-shot, U3(A), is fired which brings down ENABLE, U1 pin-15, disabling the pulse width modulator U1 output. Also, U3(A) turns on Q1 discharging C16. While pulse width modulator U1 is disabled by U3(A), U3(B) resets U4 output by turning on Q2, setting the protection circuits ready for the next cycle. Approximately two seconds later from the beginning of the protection trigger at U4, outputs of U3(A) return to the initial state, (pin 6 to low and pin 7 to high), turning off Q1. Then capacitor C16 is being charged through R25,

and the voltage at U1 pin 6 will gradually drop, enabling pulse width modulator to increase the pulse width. This is called soft start. If overload still exists, the protection circuit cycles again. When the overload no longer exists, the power supply resumes normal operations.

### 2-365. A5A3 AUXILIARY TRANSFORMER PCB CIRCUIT ANALYSIS

2-366. Refer to the Power Supply Schematic in the Schematic Manual. Negative temperature coefficient thermistors RT1 and RT2 reduce the surge current when the main switch on the rear panel is turned on. When the switching power supply is running, thermistors RT1 and RT2 are shorted out by relay K1 which is energized by +5V DC from the series pass regulator.

2-367. When the AC line voltage selector switch is set to 115V, two primary windings of transformer T1 are connected in parallel. When the voltage selector switch is set to 230V, the two primary windings are connected in series. The secondary winding is bridge rectified and filtered by diodes CR2 through CR5 and capacitor C2. Transistor Q1, and diodes CR6 and CR7 form a +24V DC regulator that provides power to the oven oscillator when it is installed. Resistors R4, R5, and transistor Q2 provide current limiting. This +24V DC is also used to light the STDBY light on the front panel. Regulator U1 provides +13V DC (nominal) which is used to energize the A5A2 Regulator PCB. During start-up of switching supply. Also this line, +12V DC, is routed to the front panel assembly through the A5A1 Power Supply PCB, A5A6 Power Supply Capacitor PCB, and the A6A2 Motherboard PCB to energize the thermal shutdown and the +5V DC power-on sense circuits.

### 2-368. A5A6 POWER SUPPLY CAPACITOR PCB CIRCUIT ANALYSIS

2-369. Refer to the A5A6 Power Supply Capacitor PCB Schematic in the Schematic Manual. Capacitors C1 through C5 are filter capacitors for normal mode noise. Capacitors C6, C8, and C9 are for common mode noise. Inductor L1 and Capacitor C7 are used to prevent conducted emissions from the switching supply to the output of the +5V DC series-pass regulator.

### 2-370. A6A2 MOTHERBOARD PCB CIRCUIT ANALYSIS

2-371. Refer to the A6A2 Motherboard PCB Schematic in the Schematic Manual. All the pre-regulated DC lines, nominally +6V,  $\pm$ 13V, and +25V are distributed to the appropriate series-pass regulators which plug into the motherboard. The regulated outputs, +5V,  $\pm$ 12V, +24, are distributed to the appropriate output terminals, J4 through J7. Inductor L1 and capacitor C7 suppress noise generated by the fan from being conducted back to the +13V line. The +24 volt supply to the oven oscillator is derived from the switching supply when the instrument is on, and from the auxiliary power supply when in STDBY.

For overload protection, all of the output voltages of the series-pass regulators are monitored through J6 pin 13 by Q1 and Q2 and associated components (Figure 2-17, below). When the output voltages are normal, nominally zero voltage appears at the base of Q2 and the emitter of Q1, keeping Q1 and Q2 turned off. If any one of the series-pass regulators is shorted to ground, either Q1 or Q2 will become active, drawing current out of the ON/STDBY line. This causes the output of pulse width modulator U1 on A5A2 Regulator PCB to narrow, reducing the output voltages from the switching power supply.

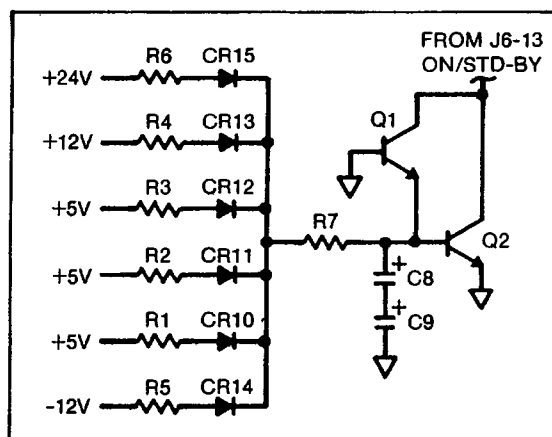

Figure 2-17. Overload Protection, Simplified Schematic

#### 2-372. A6A4 +24V, +12V, -12V SERIES-PASS REGULATOR PCB CIRCUIT ANALYSIS

2-373. Refer to the A6A4 Series Pass Regulator PCB Schematic in the Schematic Manual. The +25 volts from the switching power supply is applied to Q5. The output from Q5, +24V, is monitored by U3 through a voltage divider R4, R5, and R6. Zener diode CR1 provides the reference 6.4V DC to the error amplifier U3. Capacitor C4 reduces noise generated by the zener diode. Resistor

R19 provides a base current pass for Q5 at the time of turn-on. The output voltages of this regulator is adjusted by R5 to 24V. The +24V is used as the reference voltage from the +12V regulator whose output voltage is determined by R11 and R12. The -12V regulator output is used as the reference voltage for the -12V regulator whose output is determined by R16 and R17. Thus the output voltages of all of the series-pass regulators is set by R5. The power-up sequence of the outputs from the regulators is +24V, +12V, and -12V.

#### 2-374. A6A3 +5V SERIES-PASS REGULATOR PCB CIRCUIT ANALYSIS

2-375. There are three +5V regulators on the A6A3 Series-Pass Regulator PCB. The +5V SYNTH supplies +5V to the Synthesizer Plate, the +5V OUTPUT supplies +5V to Output Plate, and +5V DIG supplies +5V to Front Panel Assembly.

2-376. Reference voltage to each regulator is derived from the +12V regulator output. Output voltages are determined by voltage dividers, R3 and R4, R7 and R8, and R11 and R12. Output voltage sensing is done within this board. Therefore, the voltage divider resistors are chosen such that all the regulator output voltages are slightly higher than +5V in order to compensate for voltage drops in the following passes.

#### 2-377. A6A1 IEEE CONNECTOR PCB CIRCUIT ANALYSIS

2-378. The A6A1 IEEE Connector PCB contains the standard 24-pin female IEEE-488 cable connector and the IEEE-488 address switch. Refer to the System Block Diagram and the A6A1 IEEE Schematic in the 6070A/6071A Schematic Manual.

2-379. The printed circuit board is located on the rear panel under the fan assembly. The toggle switches determines the IEEE-488 address of the instrument. The A6A1 IEEE Connector PCB is connected to the A2A4 Controller Motherboard by cable W4.



## Section 3 Access Procedure

### 3-1. INTRODUCTION

3-2. The information in this section describes instrument access procedures. Each access procedure is composed of a disassembly procedure and a corresponding assembly procedure. Table 3-1 is the Access Procedure Index.

### 3-3. LOCATION OF MAJOR ASSEMBLIES

3-4. The locations of the major assemblies of the 6070A/6071A are illustrated in Figure 3-1. The synchronizer module and the output module swing out from the center cable assembly. Circuit boards are located on each side of the synchronizer module and output module. Figures 3-2 and 3-3 illustrate the circuit board locations for the synchronizer module, and Figures 3-4 and 3-5 illustrate the circuit board locations for the output module. The 6070A and 6071A can be energized for maintenance purposes when opened up as shown in Figure 3-1.

### 3-5. INTERIOR ACCESS PROCEDURE

#### 3-6. Introduction

3-7. The Interior Access Procedure allows access to the interior of the instrument. This procedure is basic to every other access procedure. Since the following disassembly and assembly procedures are simple, they are not illustrated.

#### 3-8. Disassembly Procedure

3-9. Remove the top and bottom covers to gain access to the interior of the instrument. Use the following procedures:

1. Remove the five screws along the front edge and the five screws along the rear edge of each cover.
2. Lift the covers off the instrument.

#### 3-10. Assembly Procedure

3-11. Assemble the instrument by installing the top and bottom covers using the following procedure:

1. Slide the covers back onto the instrument. Make sure that the cover slots are toward the front of the instrument. Make sure that the edge of each cover side fits onto the slots in the side rails of the instrument.
2. Fasten the covers in place using the screws removed during the disassembly procedure.

### 3-12. A3A3 AND A3A5 PRINTED CIRCUIT BOARDS ACCESS PROCEDURE

#### 3-13. Introduction

3-14. The A3A3 Delay Discriminator PCB and the A3A5 VCO PCB access procedure consists of removing the module cover. After the module cover has been removed, the cover screws must be properly torqued to insure specified RF integrity. Figure 3-6 illustrates the sequence in which the screws must be torqued.

#### 3-15. Disassembly Procedure

3-16. Complete the following procedure to gain access to the A3A3 and A3A5 printed circuit boards.

1. Set the front panel POWER control and the rear panel MAIN POWER switch to the OFF positions, and remove line power from the instrument.
2. Complete the disassembly portion of the Interior Access Procedure.
3. Remove the 13 screws and flat washers that hold the A3A3 Delay Discriminator and A3A5 VCO cover in place.

Table 3-1. Access Procedure Index

EQUIPMENT DESCRIPTION	PARAGRAPH REFERENCE	EQUIPMENT LOCATION	FIGURE REFERENCE
A1A1 Front Panel PCB	3-82	Front Panel Assembly	3-9, 3-15
A2A1 Controller PCB and A2A4 Controller PCB	3-89	Controller Assembly	3-9, 3-16
A3A2 10 MHz Reference PCB	3-10	Top of Synthesizer Module	3-2
A3A3 Delay Discriminator PCB	3-12	Top of Synthesizer Module	3-2
A3A4 N/1 Divider PCB	3-19	Top of Synthesizer Module	3-2
A3A9 Synthesizer Distribution PCB	3-19	Top of Synthesizer Module	3-2
A3A5 VCO PCB	3-12	Top of Synthesizer Module	3-2
A3A1 Phase Detector PCB	3-26	Bottom of Synthesizer Module	3-1, 3-3
A3A7 Sub-Synthesizer PCB	3-26	Bottom of Synthesizer Module	3-1, 3-3
A3A6 SSB Mixer PCB	3-26	Bottom of Synthesizer Module	3-1, 3-3
A3A8 Synthesizer Control Buffer PCB	3-26	Bottom of Synthesizer Module	3-1, 3-3
A3A10 VCO PCB	3-26	Bottom of Synthesizer Module	3-1, 3-3
A4A2 Mod Oscillator PCB	3-33	Bottom of Output Module	3-1, 3-5
A4A3 Attenuator PCB	3-40	Top of Output Module	3-4
A4A4 Modulator/Divider PCB	3-47	Top of Output Module	3-1, 3-4
A4A6 Output Amplifier PCB (X2 Output Ampl)	3-33	Bottom of Output Module	3-5
A4A7 Output Amplifier PCB	3-33	Bottom of Output Module	3-5
A4A8 Heterodyne Oscillator PCB	3-47	Top of Output Module	3-1, 3-4
A4A9 Heterodyne Converter PCB	3-33	Bottom of Output Module	3-1, 3-5
A4A10 Mod Distribution PCB	3-33	Bottom of Output Module	3-1, 3-5
A5A1 Power Supply PCB	3-54	Power Supply Assembly	3-9
A5A2 Auxiliary Power Supply PCB	3-54	Power Supply Assembly	3-9
A5A3 Auxiliary Transformer	3-54	Power Supply Assembly	3-9
A5A4 Input Rectifier PCB	3-54	Power Supply Assembly	3-9
A5A5 Switching Transistors PCB	3-54	Power Supply Assembly	3-9
A5A6 Power Supply Capacitors PCB	3-54	Power Supply Assembly	3-9
A6A1 IEEE Connector PCB	3-96	Rear Panel	3-9, 3-17



Table 3-1. Access Procedure Index (cont)

EQUIPMENT DESCRIPTION	PARAGRAPH REFERENCE	EQUIPMENT LOCATION	FIGURE REFERENCE
A6A2 Series-Pass Motherboard PCB	3-54	Power Supply Assembly	3-9
A6A3 +5 Volt Series-Pass Voltage Regulator PCB	3-54	Power Supply Assembly	3-9
A6A4 +12V, -12V, +24V, Series-Pass Voltage Regulator PCB	3-54	Power Supply Assembly	3-9
A7 Delay Cable Assembly	3-61	Delay Cable Assembly	3-11
A1/A2 Encoder Assembly	3-75	Front Panel/Controller Assembly	3-15
A1/A2 Front Panel/Controller Assembly	3-68	Front Panel/Controller Assembly	3-9

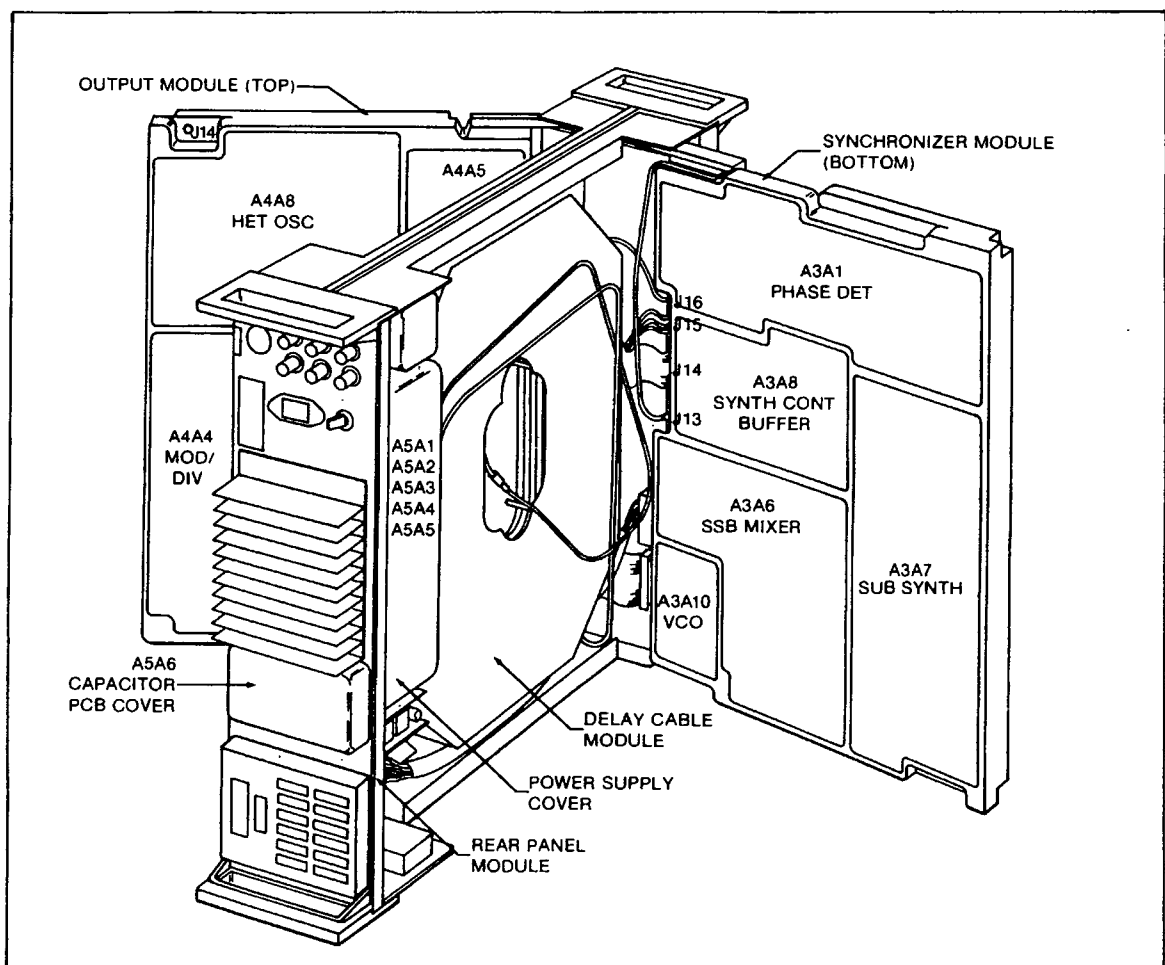

Figure 3-1. 6070A/6071A Opened for Maintenance

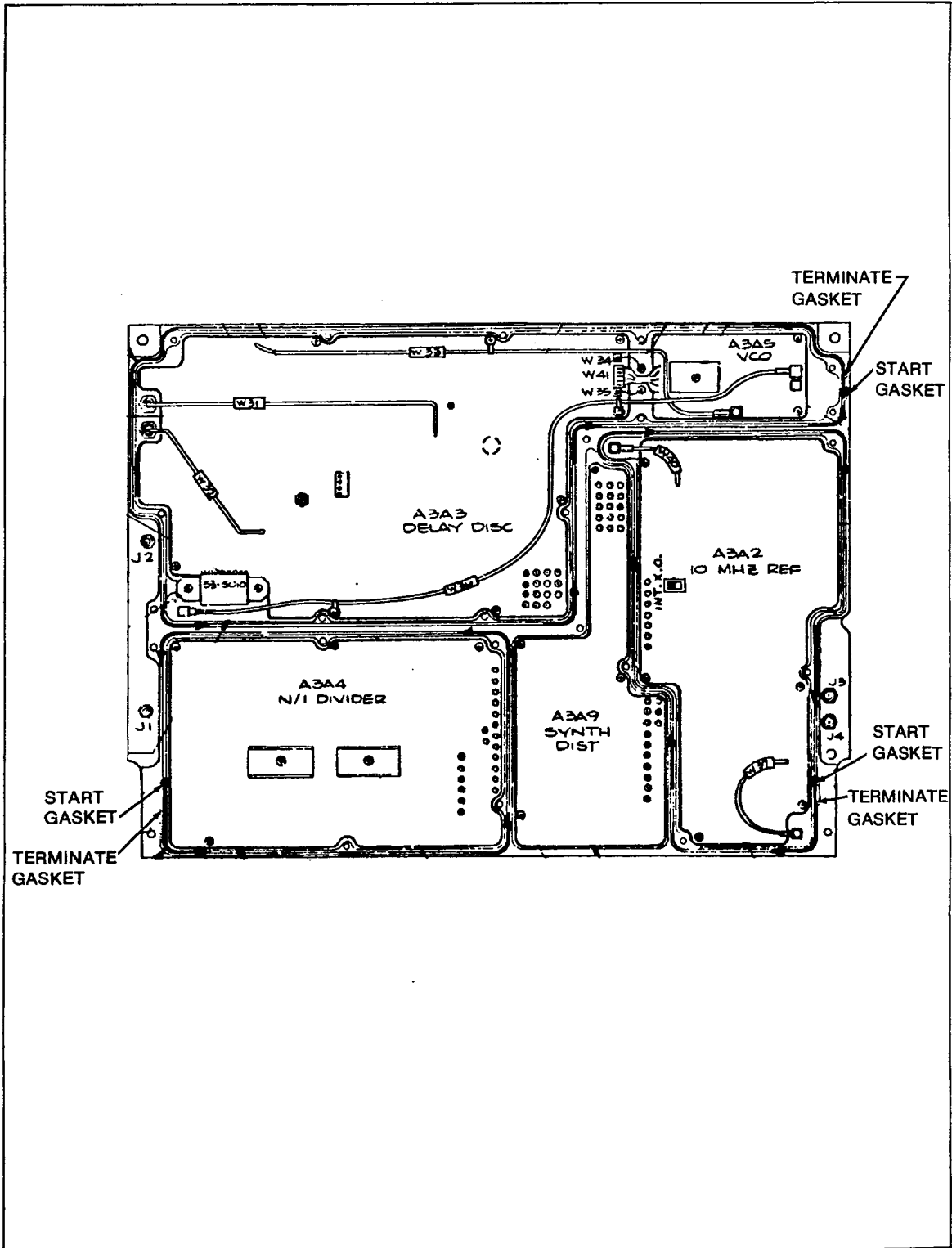

Figure 3-2. Top Synthesizer Module

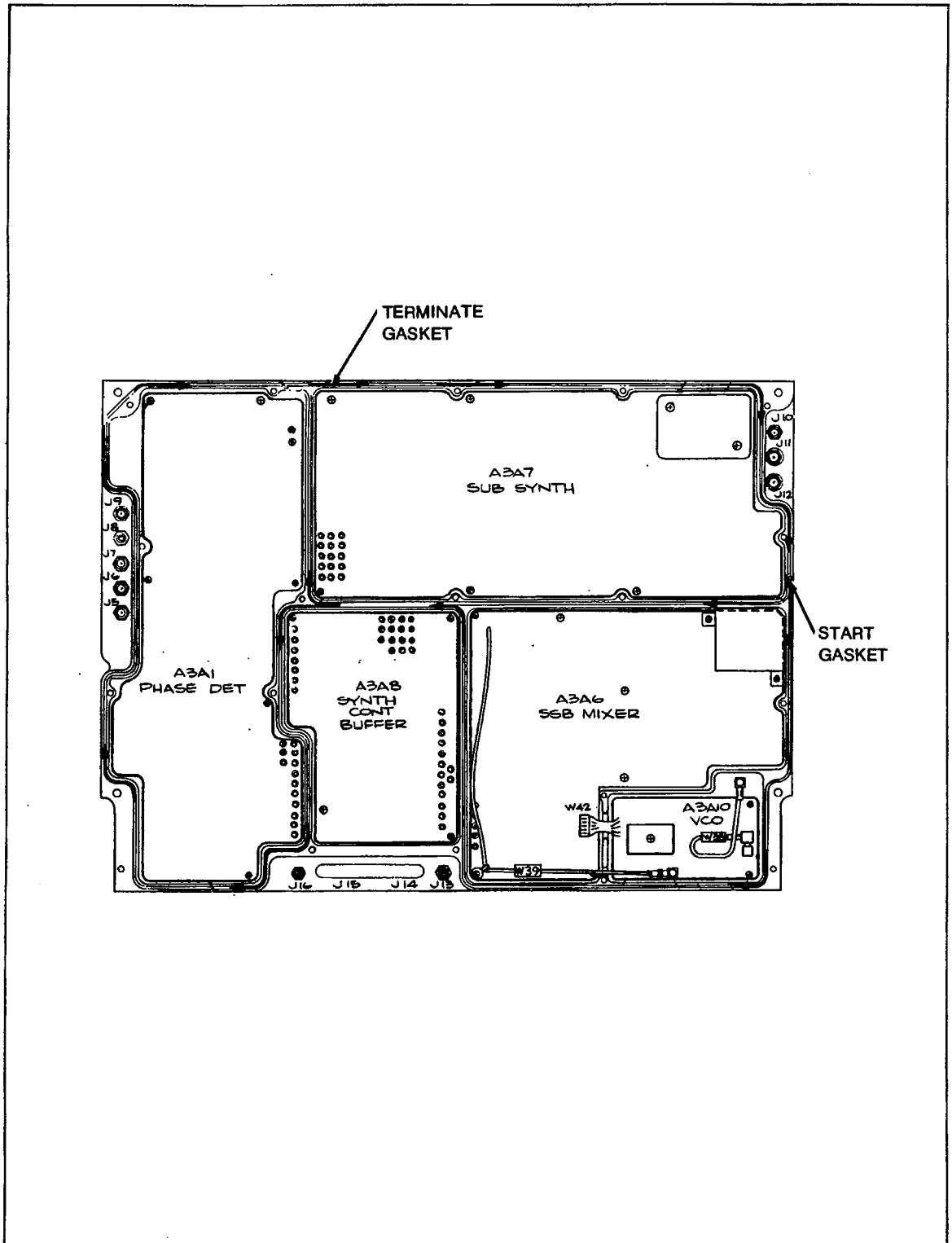

Figure 3-3. Bottom of Synthesizer Module

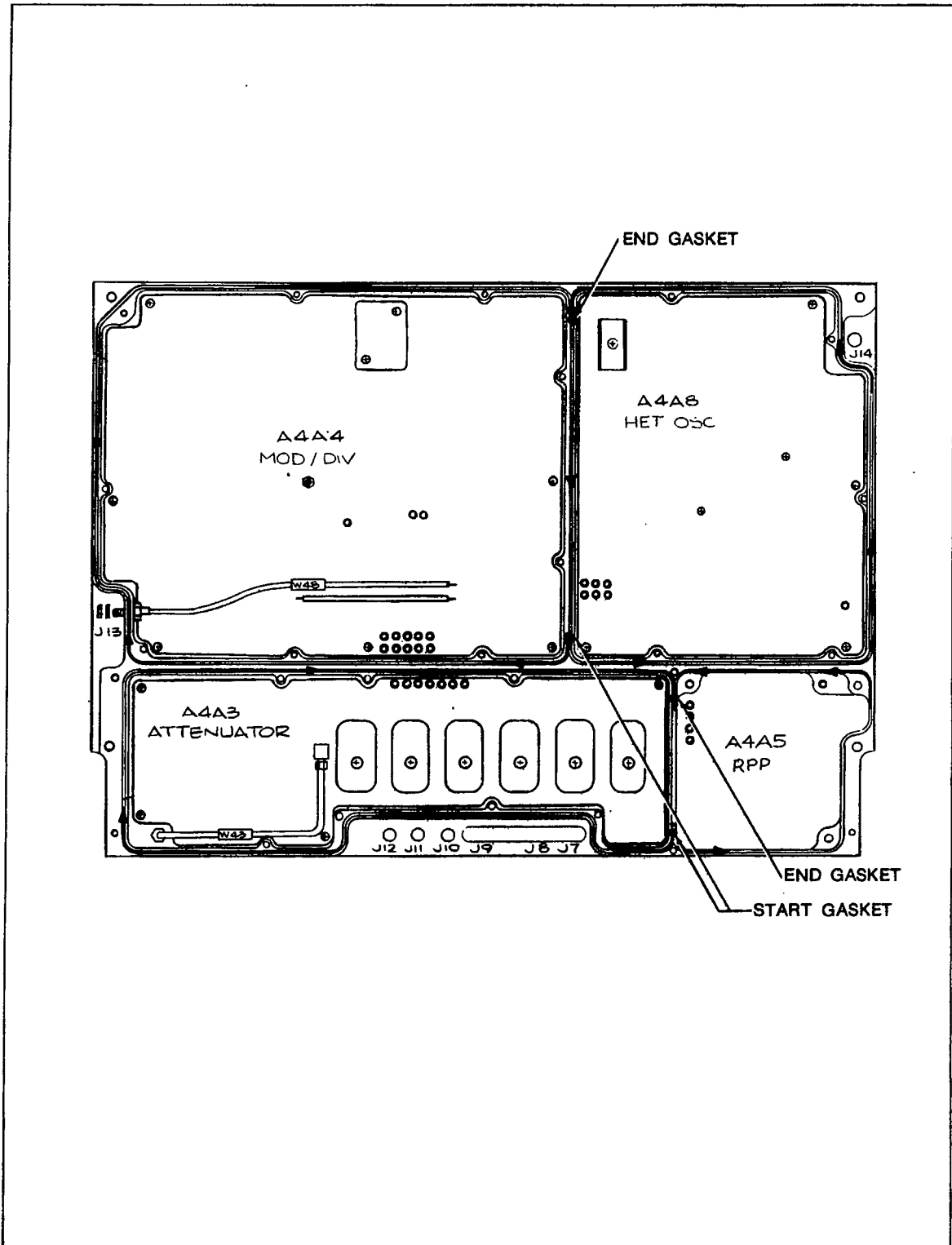

Figure 3-4. Top of Output Module

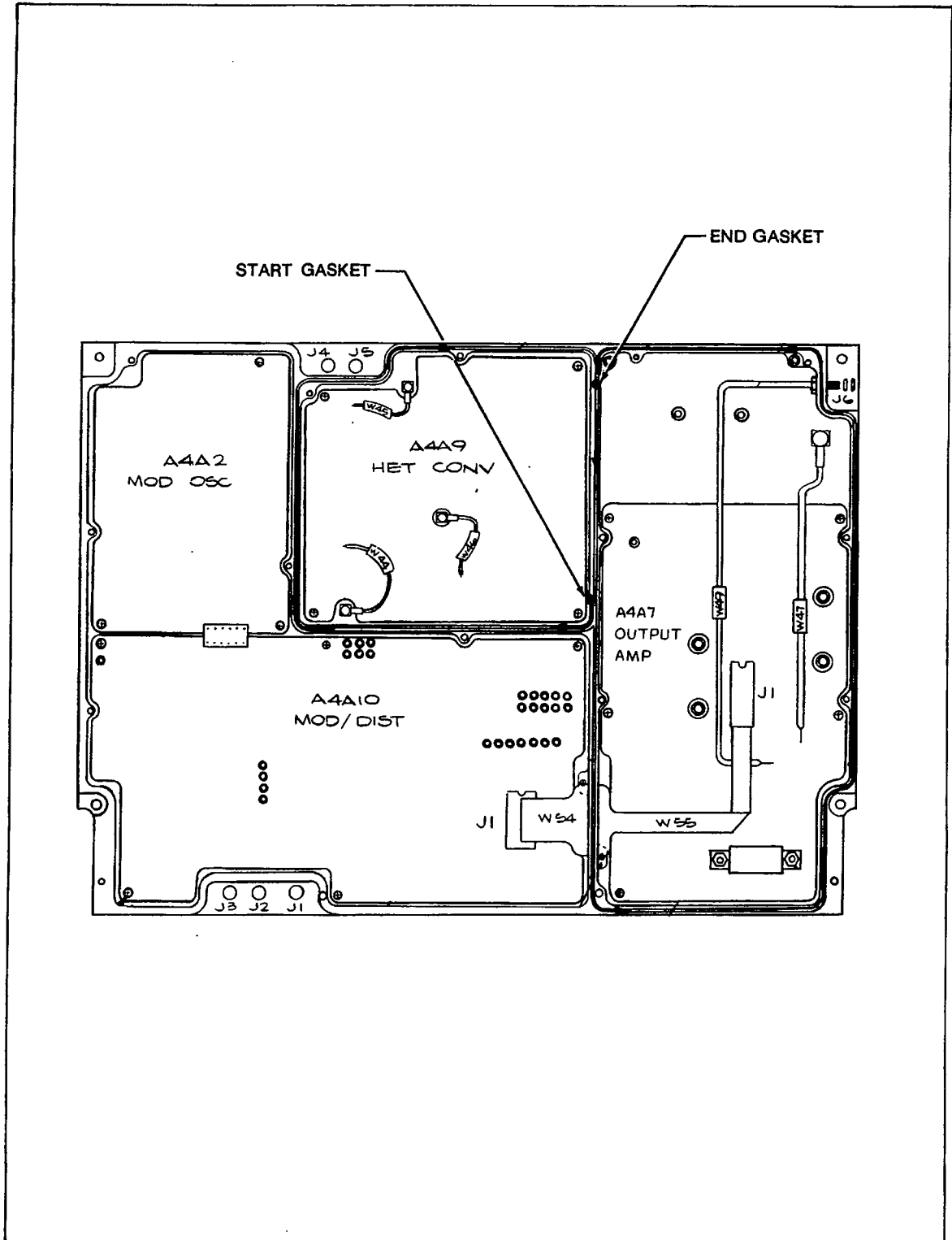

Figure 3-5. Bottom of Output Module

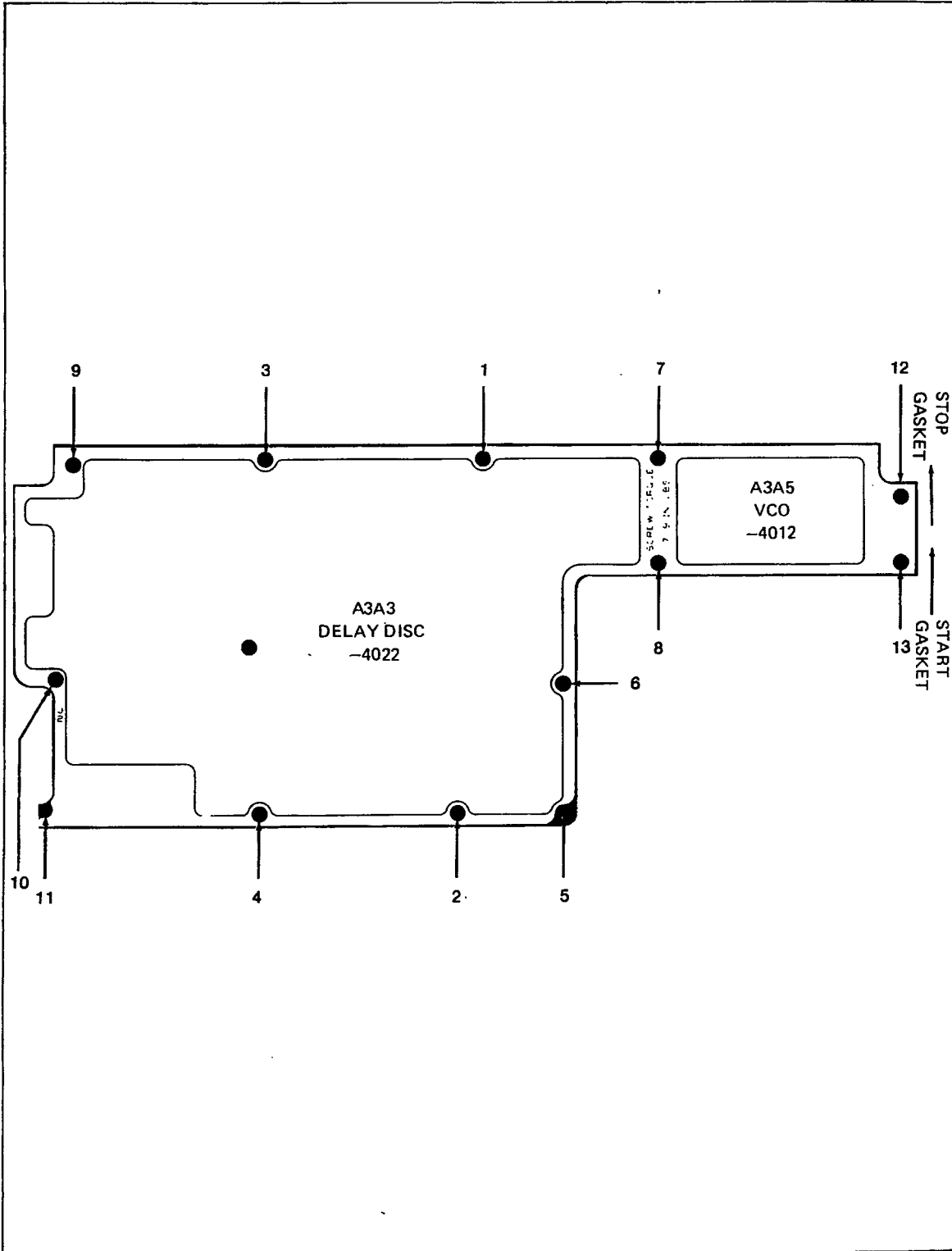

Figure 3-8. Torque Sequence, A3A3, A3A5 Cover

4. Carefully lift the cover off; do not disturb the RF gaskets under the cover.

### 3-17. Assembly Procedure

3-18. Complete the following procedure to assemble the instrument:

1. Make sure that the RF gasket is in place. The gasket should start and end as shown in Figure 3-2. Inspect the RF gaskets for damage (areas that are folded over, worn, or pinched).
2. If the RF gasket falls out, use the following steps to properly install it:
  - a. Start the RF gasket at screw number 13 (Figures 3-2 and 3-6).
  - b. Traveling counterclockwise, press the gasket into the groove.
  - c. The end of the gasket must continue past the beginning of the gasket (at screw 13) to screw 12 (Figure 3-6).
3. Lower the cover carefully and start the 13 screws through the washers. Do not tighten any of the screws.
4. A torque screwdriver is recommended to tighten all the screws. Use the following procedure:
  - a. Torque all the screws to 3 inch-pounds in the numerical sequence shown in Figure 3-6.
  - b. Torque all the screws to 7 to 9 inch-pounds in the numerical sequence shown in Figure 3-6. The torque value should be the same for all screws.

### 3-19. A3A2, A3A4, AND A3A9 PRINTED CIRCUIT BOARDS ACCESS PROCEDURE

#### 3-20. Introduction

3-21. The A3A2 10 MHz Reference PCB, the A3A4 N/1 Divider PCB, and the A3A9 Synthesizer Distribution PCB access procedure consists of removing the top cover. After the top cover has been removed, the cover screws must be torqued back in place to insure specified RF integrity. Figure 3-7 illustrates the sequence in which the screws must be torqued.

#### 3-22. Disassembly Procedure

3-23. Complete the following procedure to gain access to the A3A2, A3A4, and the A3A9 printed circuit boards.

1. Set the front panel POWER control and the rear panel MAIN POWER switch to OFF positions and remove line power from the instrument.

2. Complete the disassembly portion of the Interior Access Procedure.

3. Remove the 12 screws and flat washers that hold the A3A2, A3A4, and A3A9 cover in place.

### 3-24. Assembly Procedure

3-25. Complete the following procedure to assemble the instrument:

1. Make sure the RF gaskets are in place. The gaskets must start and end as shown in Figure 3-2. Inspect the RF gaskets for damage (areas that are folded over, worn, or pinched).
2. If the RF gaskets fall out, replace them as shown in Figure 3-2.
  - a. Insert the gasket around A3A2 in clockwise direction and press it into the groove.
  - b. Insert the gasket around A3A4 in counterclockwise direction and press it into the groove.
  - c. The end of the gasket must continue past (overlap) the beginning of the gasket as shown in Figure 3-2.
3. Lower the cover carefully and start the 12 screws through the washers. Do not tighten any of the screws.
4. Use the electric torque screwdriver to tighten all the screws. Use the following procedure:
  - a. Torque all the screws to 3 inch-pounds in the numerical sequence shown in Figure 3-7.
  - b. Torque all the screws to 7 to 9 inch-pounds in the numerical sequence shown in Figure 3-7. The torque value should be the same for all screws.

### 3-26. A3A1, A3A6, A3A7, A3A8 AND A3A10 PRINTED CIRCUIT BOARDS ACCESS PROCEDURE

#### CAUTION

To prevent damage to the coaxial cables and connectors, observe the following cautions when handling the cables or connectors.

1. Do not bend the cables.
2. Do not place excessive strain between the cables and connectors.
3. Start SMA connectors carefully, keep the connector straight with respect to the jack.

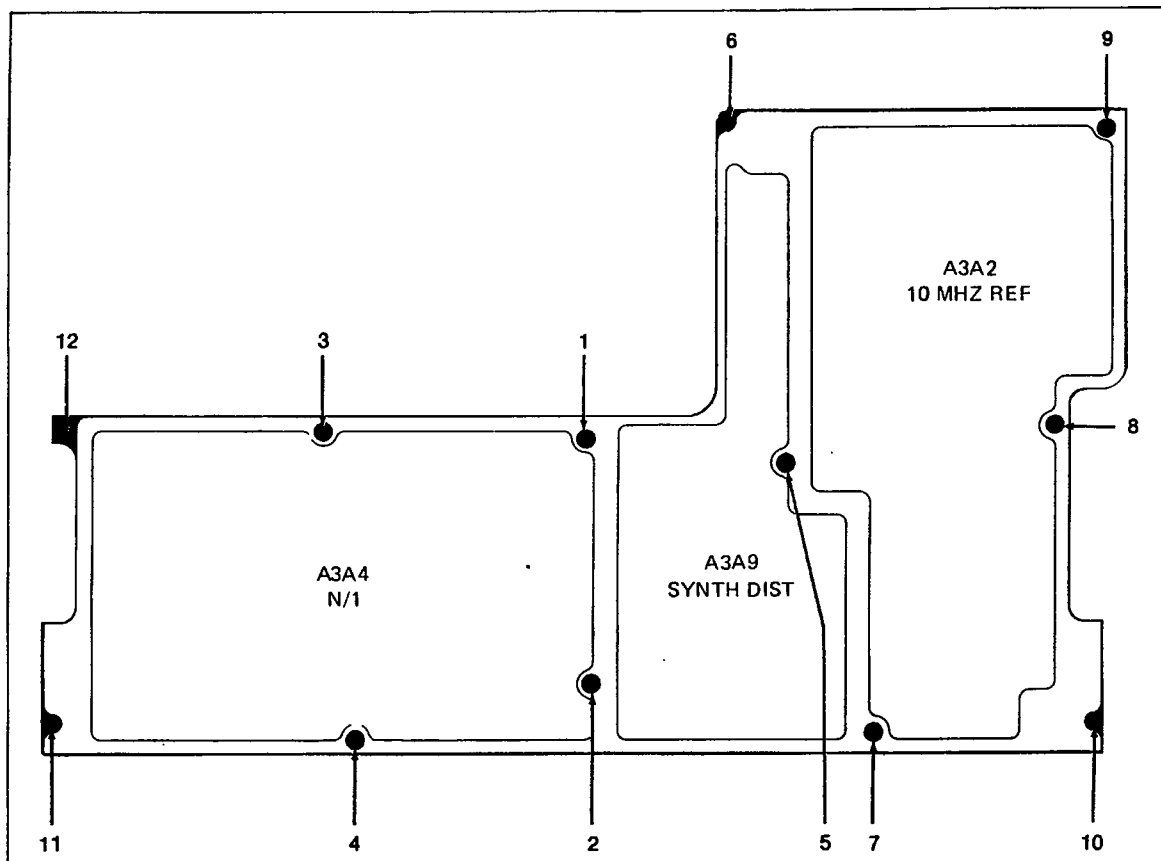

Figure 3-7. Torque Sequence, A3A2, A3A4, A3A9 Cover

### 3-27. Introduction

3-28. The A3A1 Phase Detector PCB, A3A6 SSB Mixer PCB, A3A7 Sub-Synthesizer PCB, A3A8 Synthesizer Control Buffer PCB, and the A3A10 VCO PCB are located in the bottom of the Synthesizer Module (Figures 3-1 and 3-3). The access procedure allows access to the printed circuit boards for troubleshooting procedures. After the cover has been removed, the cover screws must be torqued back in place to insure specific RF integrity. Figures 3-3, 3-8, 3-9, and 3-10 illustrate the disassembly and assembly procedures.

### 3-29. Disassembly Procedure

3-30. Complete the following procedure to gain access to the A3A1, A3A6, A3A7, A3A8, and A3A10 printed circuit boards.

1. Set the front panel POWER control and the rear panel MAIN POWER switch to the OFF position and remove line power from the instrument.
2. Complete the disassembly portion of the interior access procedure.

3. Swing the Synthesizer Module out using the following procedure:

- a. Refer to Figure 3-8 and disconnect J3, J5, J6, J7, J8, J9, J10, J11, and J12.
- b. Remove the four screws and washers (H1 and H2) and two screws (H3) shown in Figure 3-9.

4. Remove the 19 screws and washers that hold the lower cover of the Synthesizer Module in place (Figure 3-10).

5. Carefully remove the cover so that the RF gaskets under the cover are not disturbed.

6. If the instrument is to be operated (as in the procedures described in troubleshooting), jumper cables from the 6070A/6071A service kit must be installed between some of the connectors and the connections that have been disconnected.



**3-31. Assembly Procedure**

3-32. Complete the following procedure to assemble the instrument.

1. Make sure that the RF gaskets are in place (Figure 3-3) and inspect the RF gaskets for damage (areas that are folded over, worn, or pinched).

2. If any RF gasket falls out, use the following steps to properly install it:

a. Start the Rf gasket at the appropriate START GASKET point shown in Figure 3-3.

b. Traveling in the direction indicated in Figure 3-3, press the gasket into the groove.

c. The end of the gasket should be at the TERMINATE GASKET point shown in Figure 3-3.

3. Lower the cover carefully and start the 19 screws through the washers. Do not tighten any of the screws.

4. Use an electric torque screw driver to tighten all the screws. Use the following procedure:

a. Torque all the screws to 3 inch-pounds in the numerical sequence shown in Figure 3-10.

b. Torque all the screws to 7 to 9 inch-pounds in the numerical sequence shown in Figure 3-10. The torque value should be the same for all screws.

5. Swing the synthesizer module back into place using the following procedure:

a. Remove any jumper cables that may have been installed.

b. Remove the two screws (H3) from the position B holes.

**CAUTION**

To avoid cable damage when swinging the Synthesizer Module back in place, make sure that the cables between the synthesizer plate and the Delay Line are in the positions shown in Figure 3-11.

c. Swing the Synthesizer Module completely into position; make sure that the semirigid coaxial cables between the Synthesizer Module and the Delay Line are in the positions shown in Figure 3-11. This insures that these cables are not

damaged by one of the screws in the Synthesizer Module cover or by cables being crossed over one another.

d. Fasten the two screws (H3) into position A (Figure 3-9) and fasten the four washers and screws (H1 and H2) back in place.

e. Refer to Figure 3-8 and connect J3, J5, J6, J7, J8, J9, and J10.

6. Complete the assembly portion of the Interior Access Procedure.

**3-33. A4A2, A4A6, A4A7, A4A9, AND A4A10 PRINTED CIRCUIT BOARDS ACCESS PROCEDURE****3-34. Introduction**

3-35. The A4A2 Mod Oscillator PCB, A4A6 X2 Output Amplifier PCB, A4A7 Output Amplifier PCB, A4A9 Heterodyne Converter PCB, and A4A10 Mod Distribution PCB are located in the bottom of the Output Module (Figure 3-5). The A4A7 Output Amplifier PCB is used only in the Model 6070A instruments. The A4A6 X2 Output Amplifier PCB is used only in the Model 6071A instruments. The access procedure allows access to the printed circuit boards for troubleshooting procedures. After the cover has been removed, the cover screws must be torqued back in place to insure specific RF integrity. Figures 3-5 and 3-12 illustrate the disassembly and assembly procedures.

**3-36. Disassembly Procedure**

3-37. Complete the following procedure to gain access to the A4A2, A4A6, A4A7, A4A8, A4A9 and A4A10 printed circuit boards.

1. Set the front panel POWER control to STBY. Set the rear panel MAIN POWER switch to OFF. Disconnect the instrument from line power.

2. Complete the disassembly portion of the Interior Access Procedure.

3. Remove the screws and washers that hold that bottom cover of the output module in place (Figure 3-12).

4. Carefully lift the cover off; do not disturb the RF gaskets under the cover.

**3-38. Assembly Procedure**

3-39. Complete the following procedure to assemble the instrument:

1. Make sure the RF gaskets are in place (Figure 3-5) and inspect the RF gaskets for damage (areas that are folded over, worn, or pinched).

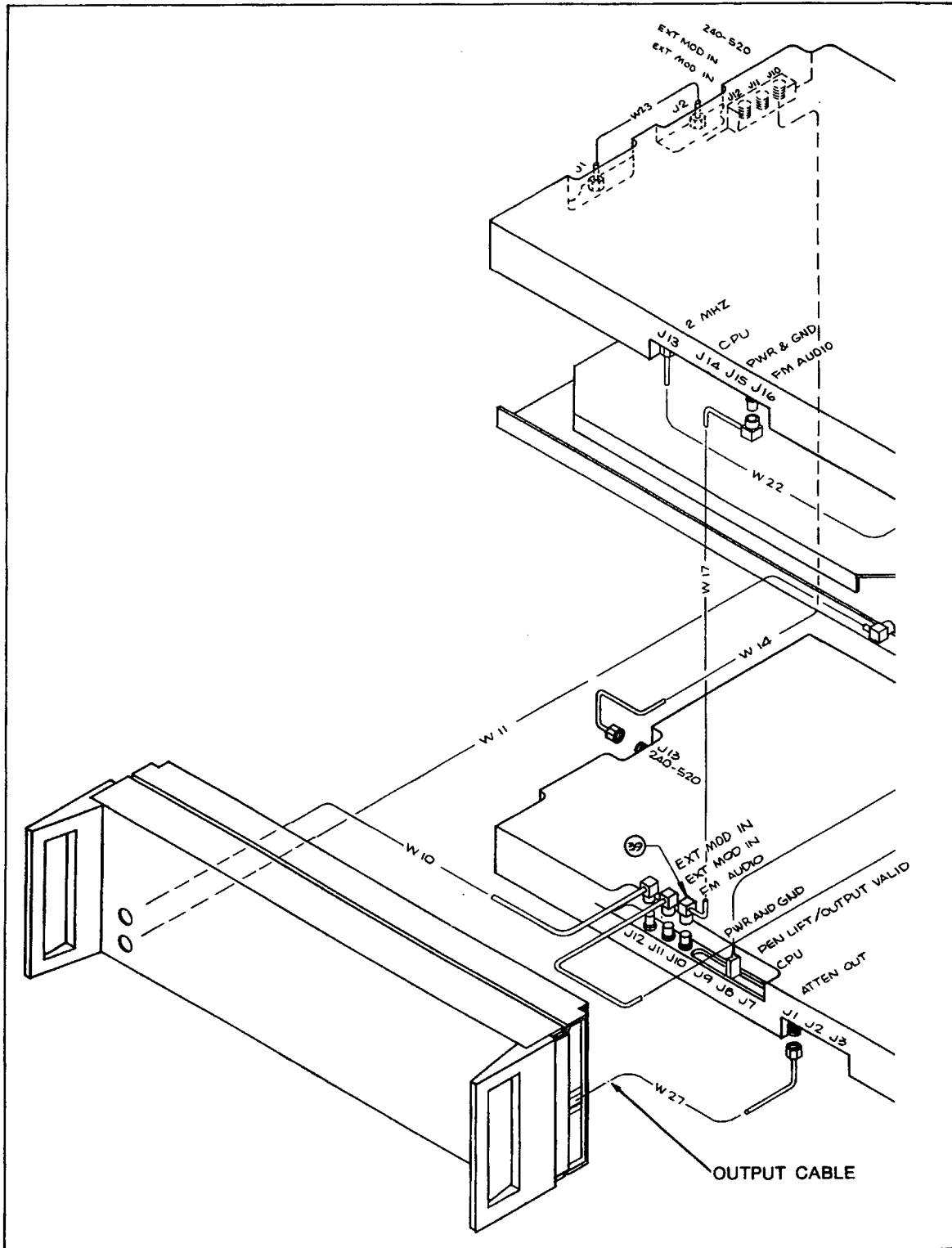

Figure 3-8. Access I

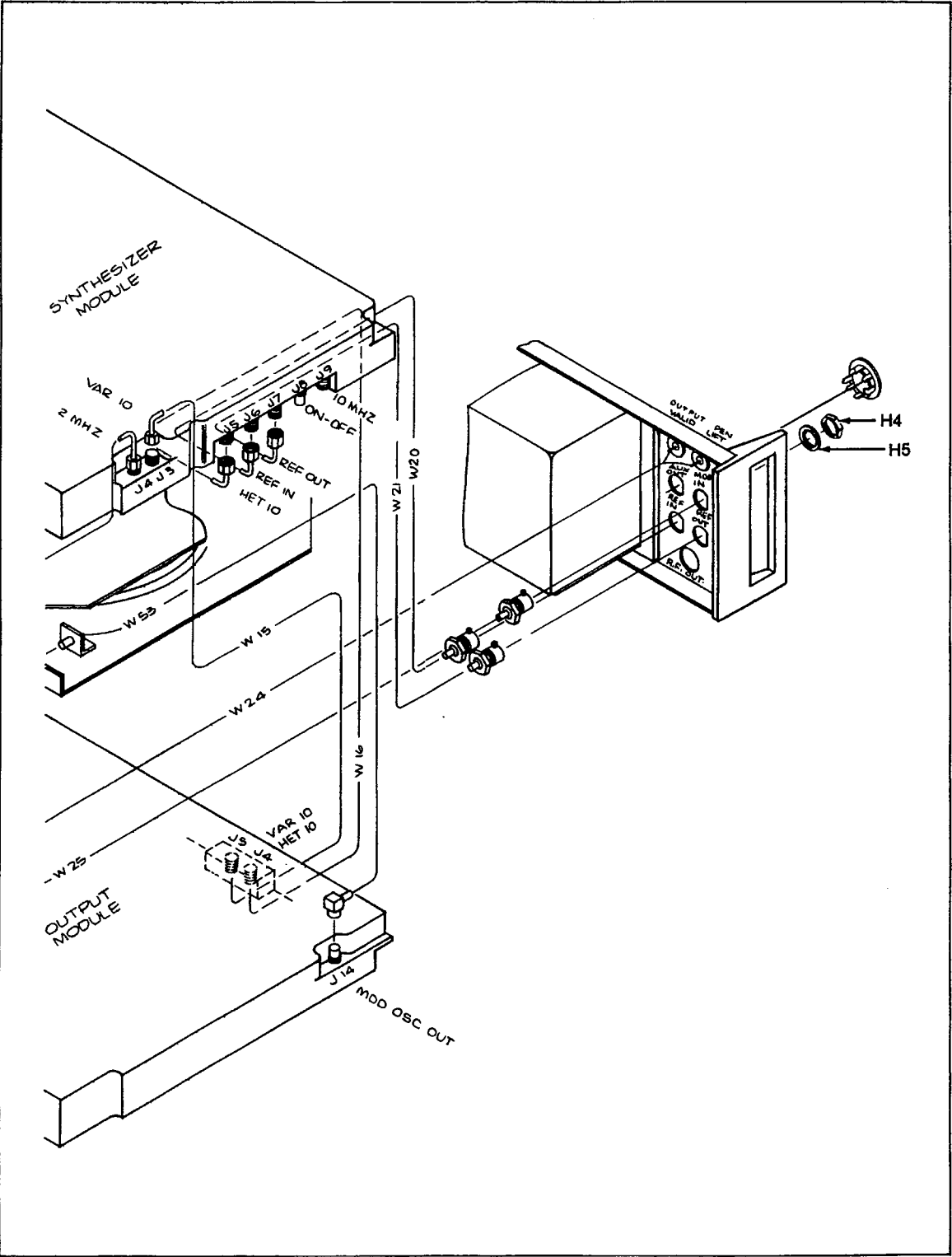

Figure 3-8. Access 1 (cont)

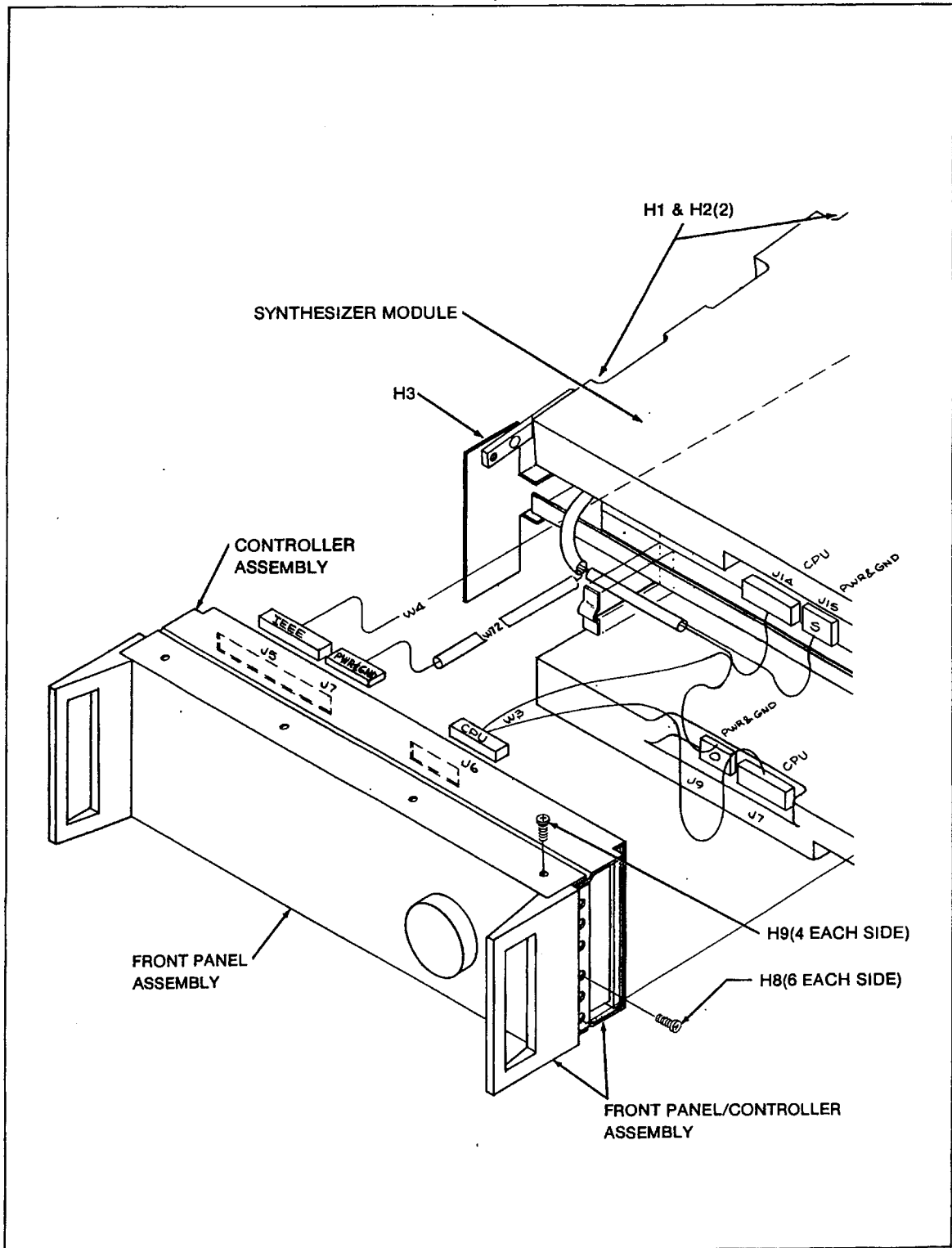

Figure 3-9. Access II

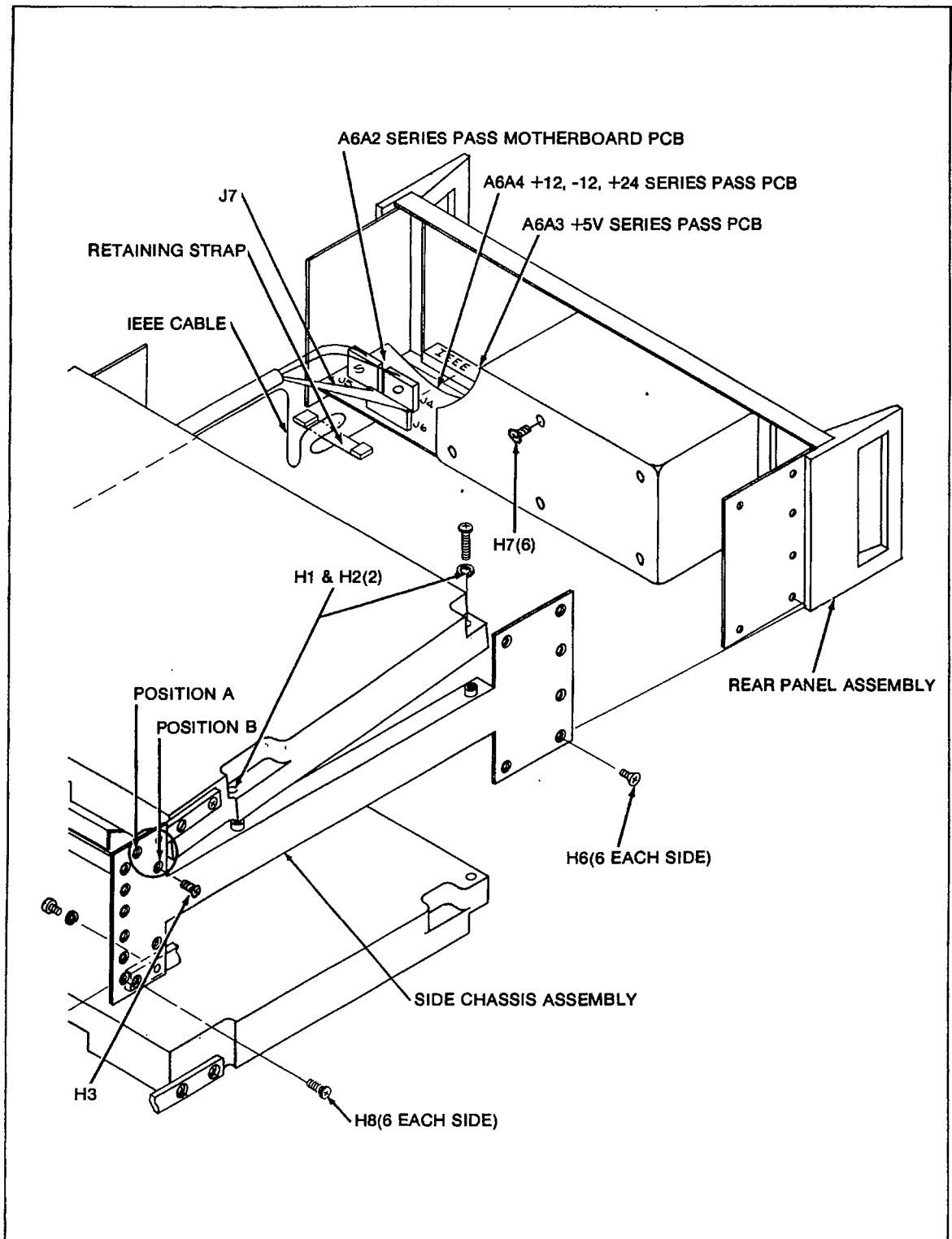

Figure 3-9. Access II (cont)

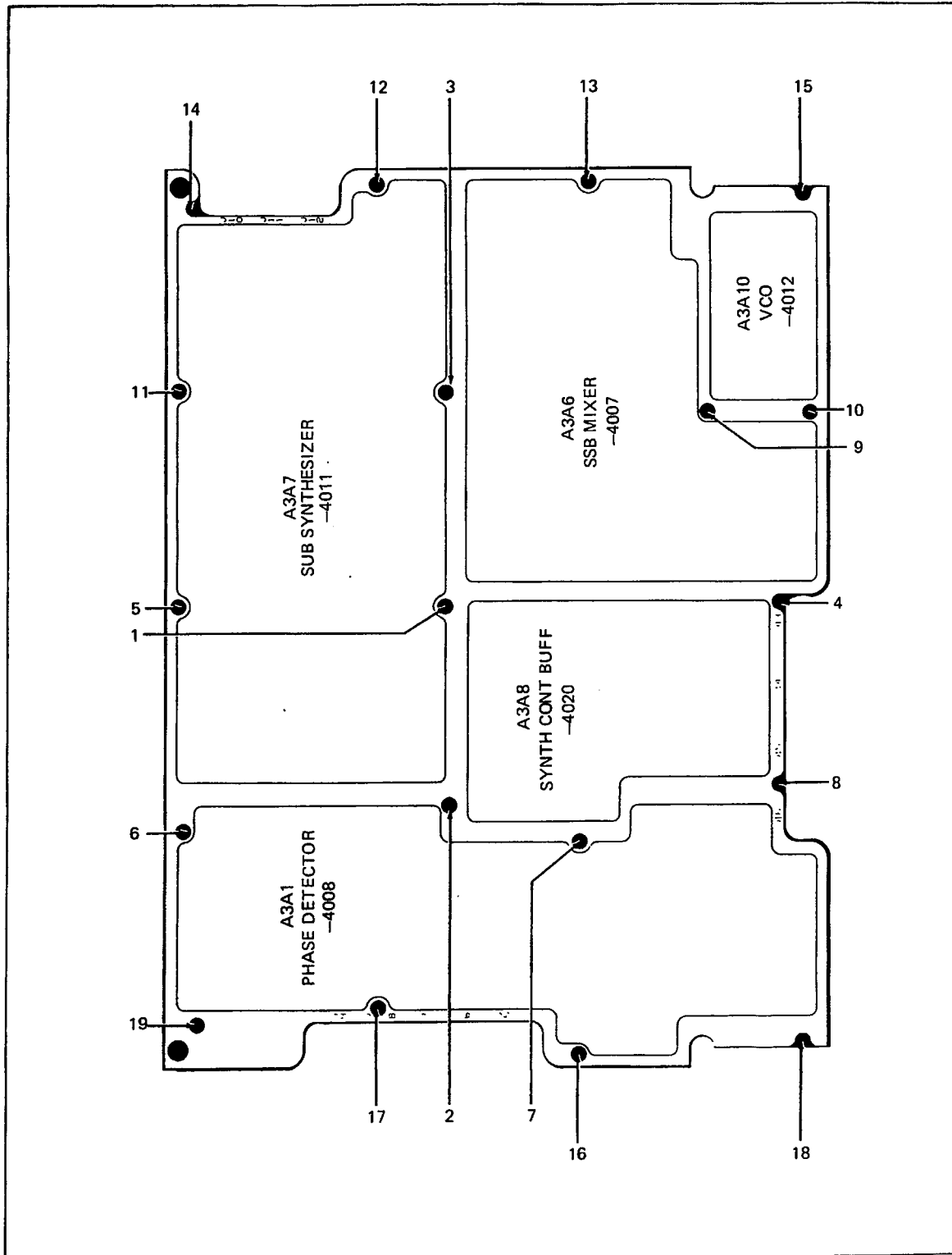

Figure 3-10. Torque Sequence, Bottom Cover of the Synthesizer Module

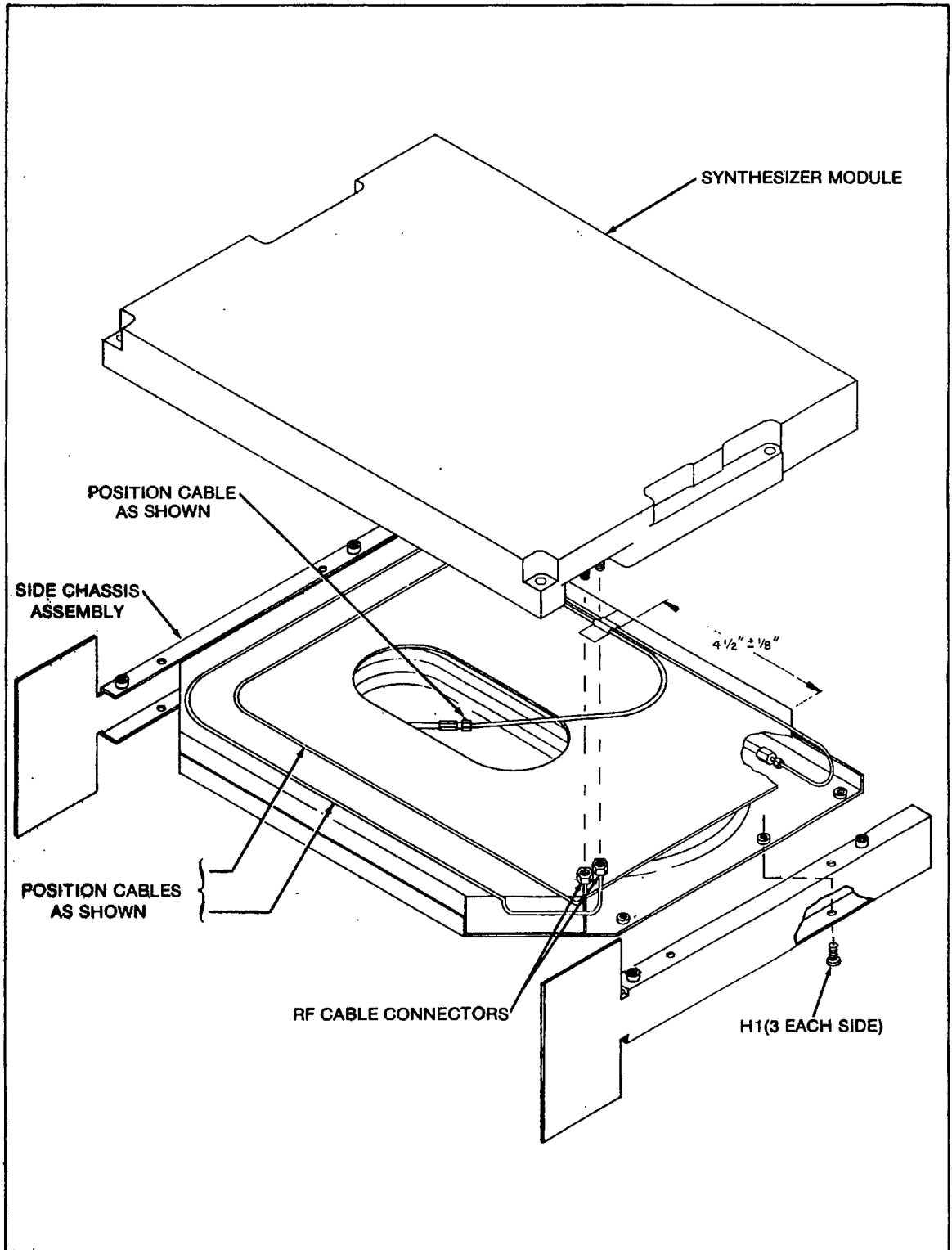

Figure 3-11. Cable Locations

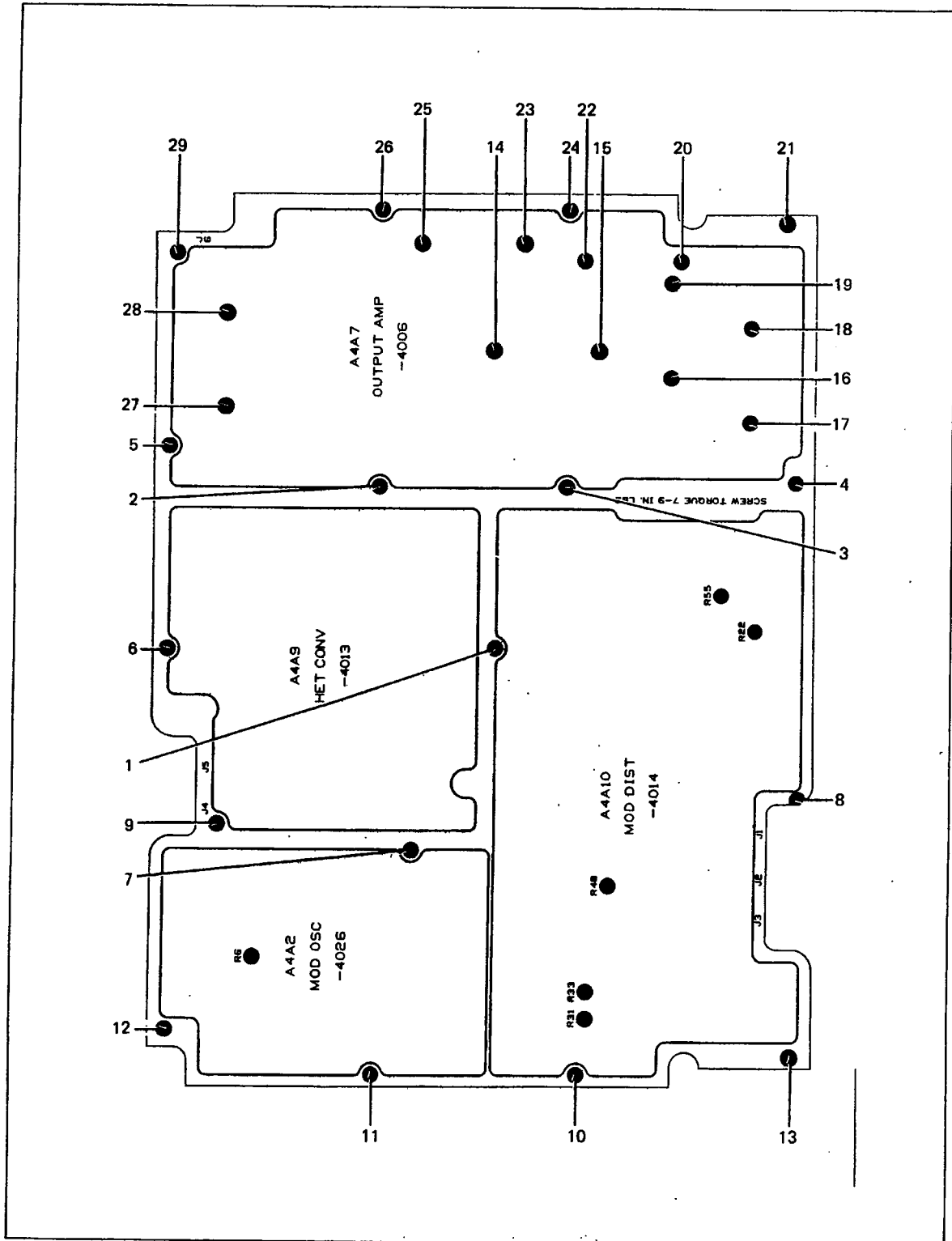

Figure 3-12. Torque Sequence, Output Module, Bottom Cover



2. If a RF gasket falls out, use the following steps to properly install it.

a. Start the gasket at the appropriate START GASKET point shown in Figure 3-5.

b. Traveling in the direction indicated, press the gasket into the groove.

c. The end of the gasket should be at the TERMINATE GASKET point shown in Figure 3-5.

3. Lower the cover carefully in place and start all the screws through the washers. Do not tighten the screws.

4. Use an electric torque screwdriver to tighten all the screws according to the following procedure:

a. Torque all screws to 3 inch-pounds in the numerical sequence shown in Figure 3-12.

b. Torque all screws to 7 to 9 inch-pounds in the numerical sequence shown in Figure 3-12. The torque value should be the same for all screws.

5. Complete the assembly portion of the Interior Access Procedure.

### 3-40. A3A3 PRINTED CIRCUIT BOARD ACCESS PROCEDURE

#### CAUTION

To prevent damage to the coaxial cables and connectors, observe the following cautions when connecting the cables and connectors.

1. Do not bend the cables.

2. Do not place excessive strain between the cables and connectors.

3. Start SMA connectors carefully; keep the connector straight with respect to the jack.

### 3-41. Introduction

3-42. The A3A3 Attenuator printed circuit boards are located in the top of the Output Module (Figures 3-1 and 3-4). The access procedure allows access to the printed circuit board for maintenance procedures. After the cover has been removed, the cover screws must be torqued back in place to insure specific RF integrity. Figures 3-4, 3-8, 3-9, and 3-13 illustrate the disassembly and assembly procedures.

### 3-43. Disassembly Procedure

3-44. Complete the following procedure to gain access to the A4A3 Attenuator PCB.

1. Set the front panel POWER control to STBY. Set the rear panel MAIN POWER control to OFF. Remove line power from the instrument.

2. Complete the disassembly portion of the interior access procedure.

3. Complete the following steps to swing out the Output Module:

a. Refer to Figure 3-8 and disconnect J1, J4, J5, J13, and J14.

b. Remove the four screws and washers (H1 and H2) and the two screws (H3) shown in Figure 3-9.

c. Lift the Output Module until J10, J11, and J12 can be reached. Disconnect J10, J11, and J12.

d. Swing the module out 90 degrees and lock it in this position by installing the two screws (H3) in position B (Figure 3-9). Remove the A4A3 and A4A5 cover screws (Figure 3-13).

4. Carefully lift the cover off; do not disturb the RF gasket under the cover.

5. If the instrument is to be operated (for troubleshooting procedures) jumper cables from the 6070A/6071A Service Kit must be installed. For maintenance procedures install two jumper cables: one from A4AJ5 to A3AJ3 and one from A4AJ13 to A3AJ10.

### 3-45. Assembly Procedure

3-46. Complete the following procedure to assemble the instrument:

1. Remove the jumper cables that have been installed.

2. Make sure the RF gaskets are in place (Figure 3-4) and inspect the RF gaskets for damage (areas that are folded over, worn, or pinched).

3. If a RF gasket falls out, use the following steps to properly install it:

a. Start the gasket at the START GASKET point shown in Figure 3-4.

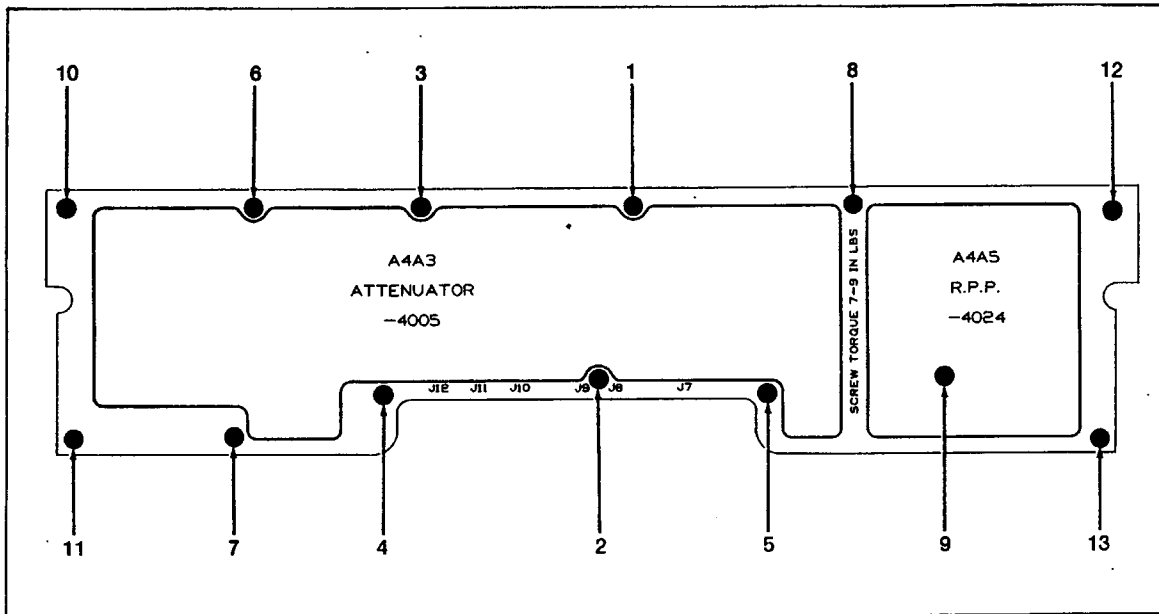

Figure 3-13. Torque Sequence, A4A3, A4A5, Top of Output Module

- b. Traveling in the direction indicated, press the gasket into the groove.
- c. The end of the gasket should be at the TERMINATE GASKET point shown in Figure 3-4.
4. Lower the cover carefully in place and start all the screws through the washers. Do not tighten any of the screws.
5. Use an electric torque screwdriver to tighten all the screws according to the following procedure:
  - a. Torque all screws to 3 inch-pounds in the numerical sequence shown in Figure 3-13.
  - b. Torque all screws 7 to 9 inch-pounds in the numerical sequence shown in Figure 3-13. The torque value should be the same for all screws.
6. Swing the Output Module back into place using the following procedures:
  - a. Remove the two screws (H3) from position B.
  - b. Swing the Output Module partially back into position.
  - c. Refer to Figure 3-8 and connected J10, J11, and J12.
  - d. Fasten the two screws (H3) into Position A (Figure 3-9) and fasten the four washers and screws (H1 and H2) back in place.
  - e. Refer to Figure 3-8 and connect J1, J4, J5, J13, and J14.
7. Complete the assembly portion of the Interior Access Procedure.

### 3-47. A4A4 AND A4A8 PRINTED CIRCUIT BOARDS ACCESS PROCEDURE

#### CAUTION

To prevent damage to the coaxial cables and connectors, observe the following cautions when handling the cables and connectors.

1. Do not bend the cables.
2. Do not place excessive strain between the cables and the connectors.
3. Start SMA connectors carefully; keep the connector straight with respect to the jack.

### 3-48. Introduction

3-49. The A4A4 Modulator/Divider and the A4A8 Heterodyne Oscillator printed circuit boards are located in the top of the Output Module (Figures 3-1 and 3-4). The access procedure allows access to the printed circuit

boards for troubleshooting procedures. After the cover has been removed, the cover screws must be torqued back in place to insure specific RF integrity. Figures 3-4, 3-8, 3-9, and 3-14 illustrate the disassembly and assembly procedures.

### 3-50. Disassembly Procedure

3-51. Complete the following procedure to gain access to the A4A4 and A4A8 printed circuit boards.

1. Set the front panel POWER control to STBY. Set the rear panel MAIN POWER control to OFF. Remove line power from the instrument.
2. Complete the disassembly portion of the Interior Access Procedure.
3. Complete the following steps to swing out the Output Module:
  - a. Refer to Figure 3-8 and disconnect J1, J4, J5, J13, and J14.
  - b. Remove the four screws and washers (H1 and H2) and the two screws (H3) shown in Figure 3-9.
  - c. Lift the Output Module until J10, J11, and J12 can be reached. Disconnect J10, J11, and J12.
  - d. Swing the module out 90 degrees and lock it in this position by installing the two screws (H3) in position B. Remove the A4A4/A4A8 cover.
4. Carefully lift the cover off; do not disturb the RF gasket under the cover.
5. If the instrument is to be operated (for troubleshooting procedures) jumper cables from the 6070A/6071A Service Kit must be installed. For the troubleshooting procedures, install two jumper cables: one from A4AJ5 to A3AJ3 and one from A4AJ13 to A3AJ10.

### 3-52. Assembly Procedure

3-53. Complete the following procedure to assemble the instrument:

1. Remove the jumper cables that have been installed.
2. Make sure the RF gaskets are in place (Figure 3-4) and inspect the RF gaskets for damage (areas that are folded over, worn, or pinched).
3. If a RF gasket falls out, use the following steps to properly install it:

a. Start the gasket at the START GASKET point shown in Figure 3-4.

b. Traveling in the direction indicated, press the gasket into the groove.

c. The end of the gasket should be at the TERMINATE GASKET point shown in Figure 3-4.

4. Lower the cover carefully in place and start all the screws through the washers. Do not tighten any of the screws.

5. Use an electric torque screwdriver to tighten all the screws according to the following procedure:

a. Torque all screws to 3 inch-pounds in the numerical sequence shown in Figure 3-14.

b. Torque all screws 7 to 9 inch-pounds in the numerical sequence shown in Figure 3-14. The torque value should be the same for all screws.

6. Swing the Output Module back into place using the following procedures:

a. Remove the two screws (H3) from position B (Figure 3-9).

b. Swing the Output Module toward the instrument until J10, J11, and J12 can be connected. Connect J10, J11, and J12 (Figure 3-8).

c. Swing the Output Module completely back into position.

d. Fasten the two screws (H3) into Position A (Figure 3-8) and fasten the four washers and screws (H1 and H2) back in place.

e. Refer to Figure 3-8 and connect J1, J4, J5, J13, and J14.

7. Complete the assembly portion of the Interior Access Procedure.

### 3-54. POWER SUPPLY ACCESS PROCEDURE

**WARNING**  
**HIGH VOLTAGES ARE EXPOSED WHEN THE POWER SUPPLY IS DISASSEMBLED. REMOVE LINE POWER BEFORE STARTING DISASSEMBLY AND ABSEVE ALL APPLICABLE SAFETY PRECAUTIONS IF LINE POWER IS RECONNECTED TO THE INSTRUMENT BEFORE THE POWER SUPPLY IS ASSEMBLED.**

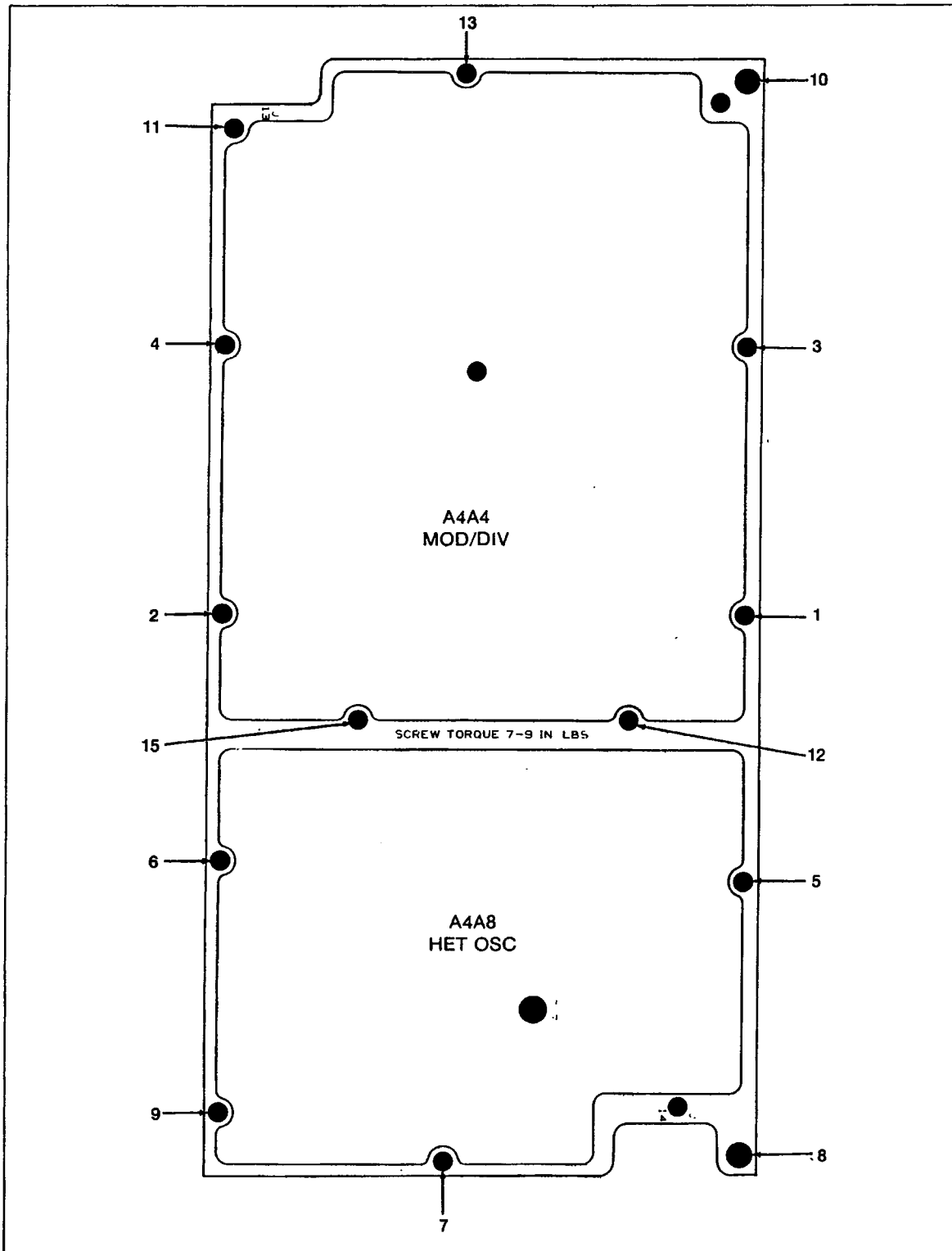

Figure 3-14. Torque Sequence, A4A4, A4A8, Top of Output Module

**3-55. Introduction**

3-56. The following procedures describe the access to all power supply PCBs and the Series Pass Voltage Regulator printed circuit boards. The power supply printed circuit boards are located in the Power Supply Assembly (Figure 3-9). The power supply printed circuit boards are: A5A1 Power Supply PCB, A5A2 Auxiliary Power Supply Regulator PCB, A5A3 Auxiliary Transformer PCB, A5A4 Input Rectifier PCB, A5A5 Switching Transistors. The A5A6 Power Supply Capacitor PCB is attached to the rear panel (Figure 3-1) and is easily accessible. The Series Pass Voltage regulator PCBs (A6A2, A6A3, A6A4) are located adjacent to the power supply assembly cover are easily accessible. Figures 3-8 and 3-9 illustrate the disassembly and assembly procedures.

**3-57. Disassembly Procedure**

3-58. Use the following procedure to access all Power Supply Assembly PCBs, and the Series-Pass Voltage Regulator PCBs.

1. Set the front panel POWER control and the rear panel MAIN POWER switch to the OFF positions and remove line power from the instrument.
2. Complete the disassembly portion of the Interior Access Procedure.
3. Remove the washers and locking nuts (H4 and H5) from the BNC and Type-N connectors at the left side (facing from the rear of the instrument) of the rear panel (Figure 3-8).
4. On the A6A2 Series Pass Motherboard PCB (directly in front of the fan), disconnect cable connectors from J4, J5, J6, and J7 (Figure 3-9).
5. Under the A6A2 Series Pass Motherboard PCB, remove the folded portion of the IEEE cable from the retaining strap (Figure 3-9).
6. Remove the 12 screws (H6) that connect the Rear Panel Assembly to the instrument.
7. If the 607XA-130 Oven Reference Option is not installed, go to step 8. If the 607XA-130 Oven Reference Option is installed, remove this option by following the 607XA-130 Disassembly procedures in Section 7.
8. Pull the Rear Panel Assembly from the instrument.
9. Rotate the Rear Panel Assembly so that it rests upon the back of the handles.

10. Remove the six screws (H7) that hold the power supply cover in place.

11. Slide the power supply cover off the power supply. The power supply is now accessible.

**3-59. Assembly Procedure**

3-60. Complete the following steps to assemble the instrument.

1. Make sure that the front panel POWER control is in the STBY position, that the rear panel MAIN POWER switch is in the OFF position, and that the instrument is disconnected from line power.
2. Slide the power supply cover in place and secure it using the six screws (H7) that were previously removed.
3. Slide the Rear Panel Assembly partially back into place. Be careful to insert all of the BNC and Type-N connectors through the appropriate holes in the Rear Panel Assembly.
4. Connect appropriate cable connectors to Series Pass Motherboard J4, J5, J6, and J7.
5. Fold the IEEE cable and insert the fold under the retaining strap.
6. Slide the Rear Panel Assembly completely into place and secure it using the 12 screws (H6, Figure 3-9).
7. Fasten the BNC and Type-N connectors to the rear panel using the washers and locknuts (H6, H5, Figure 3-8).
8. If the 607XA-130 Oven Reference Option is not supplied with this instrument go to Step 9. If the 607XA-130 Oven Reference Option is supplied, install it by following the 607XA-130 assembly procedure in Section 7 before going to Step 9.
9. Complete the assembly portion of the Interior Access Procedure.

**3-61. DELAY CABLE ASSEMBLY ACCESS PROCEDURE****CAUTION**

To prevent damage to the coaxial cables and connectors, observe the following cautions when handling the cables and connectors.

1. Do not bend the cables.
2. Do not place excessive strain between the cables and the connectors.

3. Start SMA connectors carefully; keep the connector straight with respect to the jack.

### 3-62. Introduction

3-63. The Delay Cable Assembly is located in the interior of the 6070A/6071A as shown in Figure 3-1. The access procedure allows access to remove and replace the Delay Cable Assembly. Figures 3-1, 3-8, 3-9, and 3-11 illustrate the disassembly and assembly procedures.

### 3-64. Disassembly Procedure

3-65. Complete the following procedure to gain access to the Delay Cable Assembly.

1. Set the front panel POWER control and the rear panel MAIN POWER switch to the OFF positions and remove line power from the instrument.
2. Complete the disassembly portion of the Interior Access Procedure.
3. Swing the Synthesizer Module out using the following procedure:
  - a. Refer to Figure 3-8 and disconnect J3, J5, J6, J7, J8, J9, J10, J11, and J12.
  - b. Remove the four screws and washers (H1 and H2) and two screws (H3) shown in Figure 3-9.
4. Complete the following steps to swing out the Output Module:
  - a. Refer to Figure 3-8 and disconnect J1, J4, J5, J13 and J14.
  - b. Remove the four screws and washers (H1 and H2) and the two screws (H3) shown in Figure 3-9.
  - c. Lift the Output Module until J10, J11, and J12 can be reached. Disconnect J10, J11, and J12.
5. Turn the 6070A on its side and swing the synthesizer module and output module partially out (Figure 3-1).
6. Swing the Synthesizer Module out 90 degrees and lock it in this position by installing the two screws (H3) in position B (Figure 3-9).
7. Remove the six screws that secure the cable assembly to the side chassis assembly and carefully remove the cable assembly from the 6070A (Figure 3-11).

### 3-66. Assembly Procedure

3-67. Complete the following procedure to assemble the instrument.

1. Insert the cable assembly and install the six screws that secure the cable assembly to the side chassis assembly.
2. Swing the synthesizer module back into place using the following procedure.
  - a. Remove the two screws (H3) from position B.
  - b. Swing the Synthesizer Module partially back into position.
  - c. Refer to Figure 3-8 and connect J3, J5, J6, J7, J8, J9, J1p, J11, and J12.
  - d. Fasten the two screws (H3) into position A (Figure 3-9) and fasten the four washers and screws (H1 and H2) back in place.
  - e. Complete the assembly portion of the Interior Access Procedure (paragraph 3-10).
3. Swing the Output Module back into place using the following procedure.
  - a. Swing the Output Module partially back into position.
  - b. Refer to Figure 3-8 and connect J1, J4, J5, J14, J10, J11, and J12.
  - c. Fasten the two screws (H3) into position A (Figure 3-9) and fasten the four washers and screws (H1 and H2) back in place.
  - d. Complete the assembly portion of the Interior Access Procedure.

### 3-68. FRONT PANEL/CONTROLLER ASSEMBLY ACCESS PROCEDURE

#### 3-69. Introduction

3-70. The Front Panel/Controller Assembly Access Procedure is the primary procedure to gain access to the circuit boards contained in each of the units. The procedure describes the removal of the Front Panel/Controller assembly from the 6070A/6071A. Figures 3-8 and 3-9 illustrate the disassembly and assembly procedures.

#### 3-71. Disassembly Procedure

3-72. Use the following procedure to disassemble the Front Panel/Controller Assembly from the 6070A/6071A.

1. Set the front panel POWER control and the rear panel MAIN POWER switch to the OFF positions and remove line power from the instrument.
2. Complete the disassembly portion of the Interior Access Procedure.
3. Disconnect the cables from Controller J5, J6, and J7 (Figure 3-9).
4. Disconnect the Modulation Cables from Output Module J3, J12, and J14 (Figure 3-8).
5. Remove the 12 screws (H8) that secure the Front Panel/Controller Assembly to the 6070A/6071A (Figure 3-9).
6. Remove the Front Panel/Controller Assembly from the 6070A/6071A.

### 3-73. Assembly Procedure

3-74. Complete the following steps to assemble the Front Panel/Controller to the 6070A/6071A.

1. Insert the Front Panel/Controller Assembly between the side chassis assemblies as shown in Figure 3-9.
2. Align the screw holes and install the 12 screws (H8) that secure the Front Panel/Controller Assembly to the instrument (Figure 3-9).
3. Connect the Modulation Cables from the Front Panel/Controller Assembly to the Output Module: J3, J12, and J14 (Figure 3-8).
4. Connect the appropriate cables to the Controller: J5, J6, and J7 (Figure 3-9).
5. Complete the assembly portion of the Interior Access Procedure.

### 3-75. ENCODER ASSEMBLY ACCESS PROCEDURE

#### 3-76. Introduction

3-77. The Encoder Assembly is located in the Front Panel Assembly as shown in Figure 3-15. The access procedure allows access to remove and replace the Encoder Assembly. Figures 3-9 and 3-15 illustrate the disassembly and assembly procedures.

#### 3-78. Disassembly Procedure

3-79. Use the following procedure to disassemble the encoder assembly from the Front Panel Assembly.

1. Set the front panel POWER control and the rear panel MAIN POWER switch to the OFF

positions and remove line power from the instrument.

2. Complete the disassembly portion of the Front Panel/Controller Assembly Access Procedure.
3. Remove the eight screws (H9) that secure the front panel to the Controller Assembly (Figure 3-9).
4. Disconnect the cable from J3 (Figure 3-15).
5. To remove the encoder knob, hold the tuning knob of the encoder assembly and turn the knob counterclockwise.
6. Hold the encoder and remove the three screws (H9, Figure 3-15) that hold the Encoder Assembly to the front panel and lift the assembly away from the front panel.

### 3-80. Assembly Procedure

3-81. Complete the following procedure to install the Encoder Assembly in the front panel.

1. Insert the Encoder Assembly in the front panel as shown in Figure 3-15.
2. Align the screw holes and secure the Encoder Assembly with the three screws H9 removed in the disassembly procedure (Figure 3-15).
3. Install the tuning knob by threading it onto the shaft of the Encoder. Hold the wheel of the Encoder Assembly while tightening the knob. Do not over tighten the knob on the shaft.
4. Connect the cable from the Controller Assembly to J3 (Figure 3-15).
5. Attach the Controller Assembly to the Front Panel Assembly and secure the units using the eight screws (H9) removed in the disassembly procedure (Figure 3-9).
6. Complete the assembly portion of the Front Panel/Controller Access Procedure.

### 3-82. A1A1 FRONT PANEL ASSEMBLY PRINTED CIRCUIT BOARD ACCESS PROCEDURE

#### 3-83. Introduction

3-84. The A1A1 Front Panel Printed Circuit Board is located in the Front Panel Assembly (Figures 3-9 and 3-15). The access procedure allows access to the printed circuit board for troubleshooting procedures. Figure 3-15 illustrates the disassembly and assembly procedures.

#### 3-85. Disassembly Procedure

3-86. Complete the following procedure to gain access to the A1A1 printed circuit board.

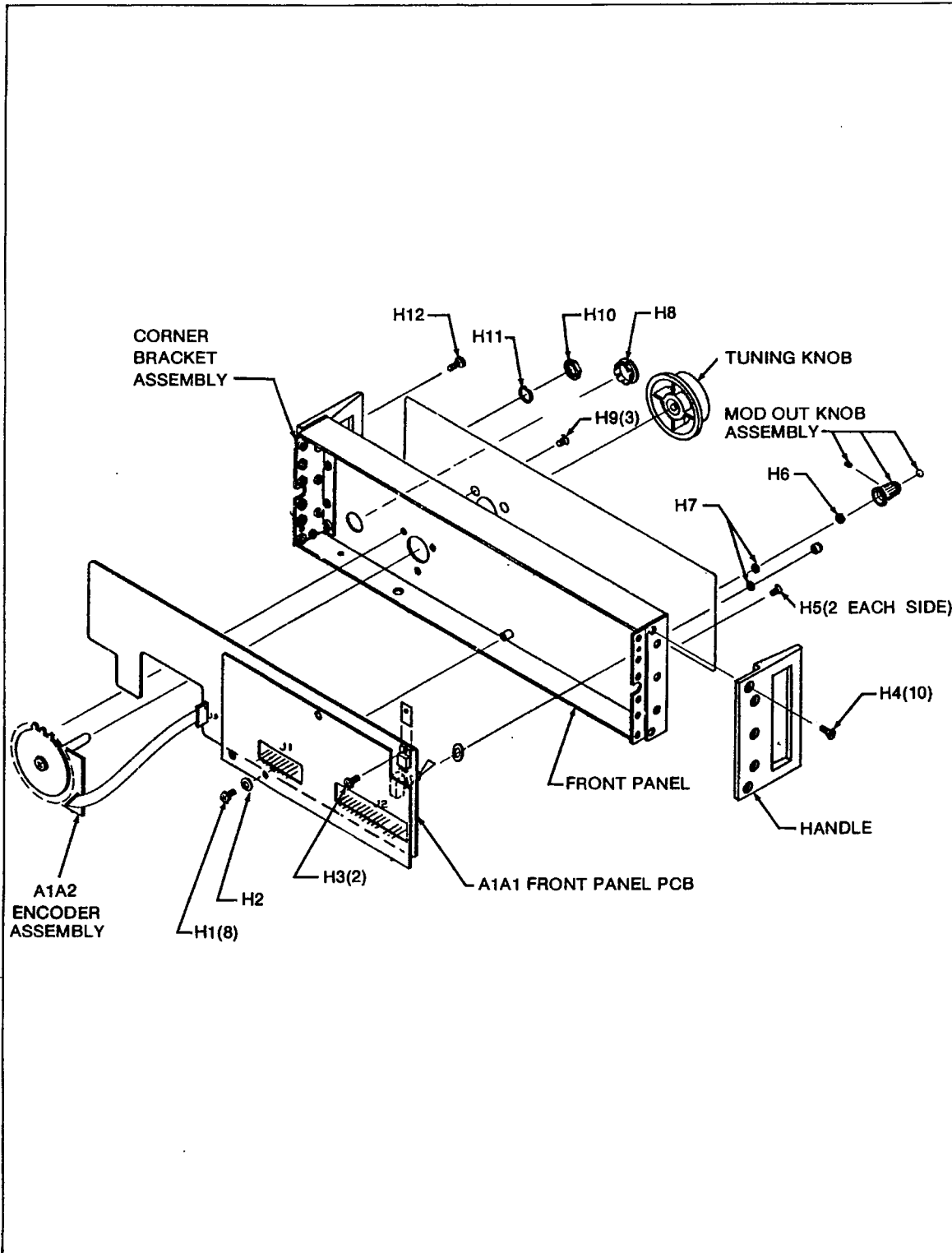

Figure 3-15. Front Panel Assembly



1. Remove the Encoder by completing the disassembly portion of the Encoder Assembly Access Procedure.

2. Disconnect the cables from J1 and J2.

3. Loosen the Allen screw in the MOD OUT knob and remove the knob from the front panel (Figure 3-15).

4. Remove the Hex nuts and washers from the BNC connectors and controls (Figure 3-15).

5. Remove the nylon screw (H3) and eight Phillips head screws (H1) that secure the A1A1 circuit board to the front panel (Figure 3-15).

6. Remove the A1A1 PCB from the front panel chassis.

### 3-87. Assembly Procedure

3-88. Complete the following procedure to assemble the instrument.

1. Orient the A1A1 PCB controls and BNC connectors with respect to the front panel chassis.

2. Carefully insert the A1A1 PCB into the front panel chassis assembly making sure controls are fully extended through the front panel.

3. Install the nylon screw (H3) and eight Phillips head screws (H1) removed in the disassemble procedure (Figure 3-15).

4. Install the washers and hex nuts to the appropriate BNC connectors and controls.

5. Install the knob on the MOD OUT control and tighten the allen screw (Figure 3-15).

6. Connect the cables to J1 and J2.

7. Complete the assembly portion of the Encoder Assembly Access Procedure.

### 3-89. A2A1 CONTROLLER PRINTED CIRCUIT BOARD ACCESS PROCEDURE AND A2A4 CONTROLLER MOTHERBOARD ACCESS PROCEDURE

#### 3-90. Introduction

3-91. The A2A1 Controller Printed Circuit Board and the A2A4 Controller Motherboard are located in the Controller Assembly. The access procedure allows access to the printed circuit boards for troubleshooting procedures. Figures 3-9 and 3-16 illustrate the disassembly and assembly procedures.

### 3-92. Disassembly Procedure

3-93. Complete the following procedure to gain access to the A2A1 Controller PCB.

1. Complete the disassembly portion of the Front Panel/Controller Access Procedure

2. Remove the eight screws (H9) that secure the Controller Assembly to the Front Panel Assembly (Figure 3-9).

3. Disconnect the cables from J3 and J4 on the Controller Assembly (Figure 3-16).

4. Remove the RF OUTPUT connector from Controller Chassis Assembly (Figure 3-16).

5. Remove the six screws (H4) from the shield and lift the shield away from Controller Assembly (Figure 3-16).

6. If the unit contains the accessory A2A2 Nonvolatile Memory PCB, remove the five screws (H3) that secure the A2A2 Nonvolatile Memory PCB and remove the circuit board (Figure 3-16).

7. Remove the seven screws (H1) from A2A1 Controller PCB and remove the circuit board from the Controller Chassis (Figure 3-16).

8. Remove the six screws (H5) from the A2A4 Controller Motherboard and remove the motherboard from the Controller Chassis Assembly (Figure 3-16).

### 3-94. Assembly Procedure

3-95. Complete the following procedure to assemble the instrument.

1. Insert the A2A4 Controller Motherboard into the Controller Chassis Assembly and secure it using the six screws (H5) removed in the disassembly procedure.

2. Insert the A2A1 Controller PCB into the Controller Chassis Assembly and secure it using the seven screws (H1) removed in the disassembly procedure (Figure 3-16).

3. If the unit is supplied with the optional accessory A2A2 Nonvolatile Memory PCB, install the A2A2 PCB in place, and secure it using the five screws (H3) removed in the disassembly procedure (Figure 3-16).

4. Install the shield and secure it using the six screws (H4) removed in the disassembly procedure (Figure 3-16).

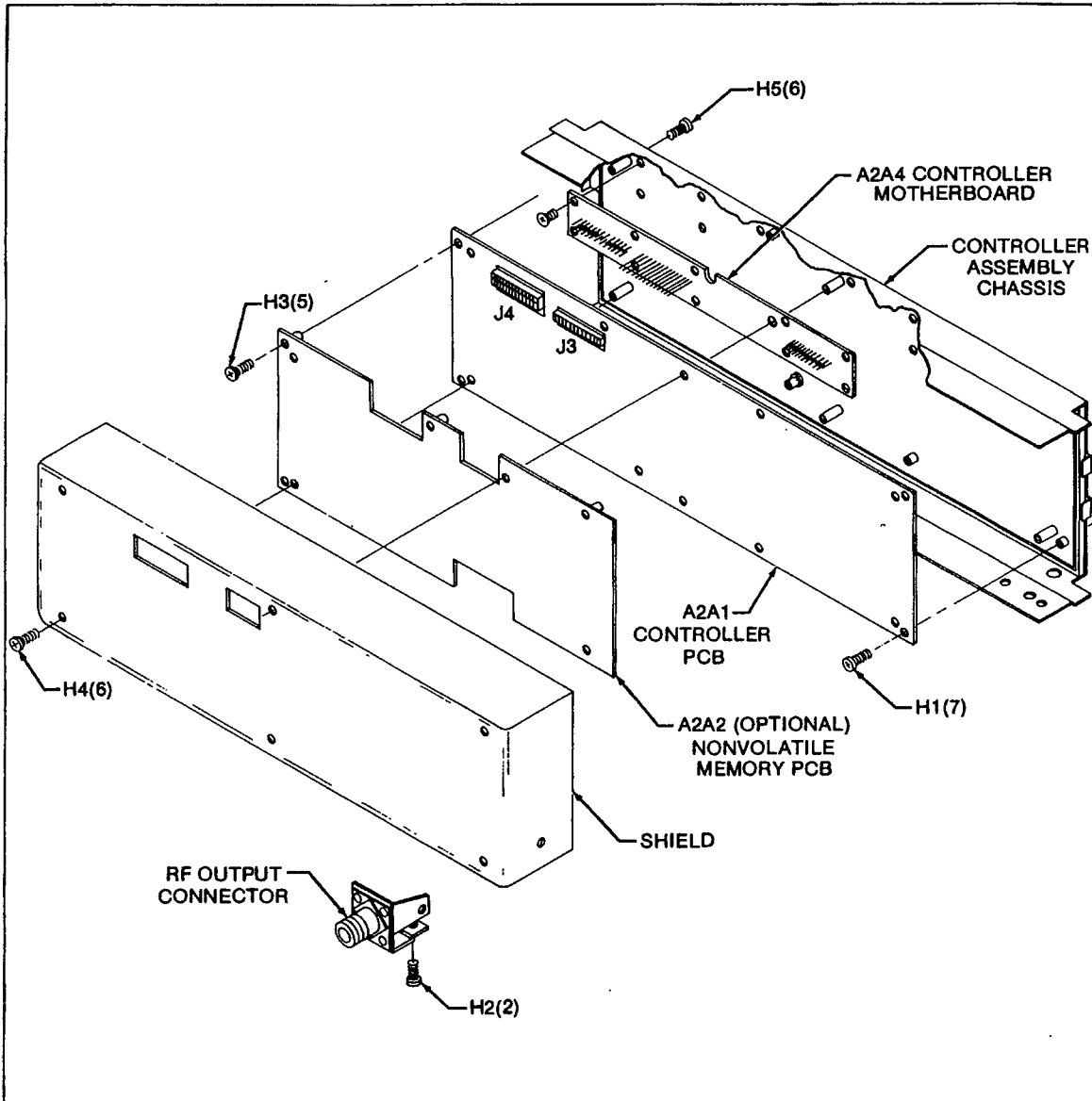

**Figure 3-16. Controller Assembly**

5. Install the RF OUTPUT CONNECTOR to the Controller Assembly Chassis and secure it using the two screws (H2) (Figure 3-16) removed in the disassembly procedure (Figure 3-16).

6. Connect cables to J3 and J4 then assemble the Controller Assembly to the Front Panel Assembly.

7. Secure the units using the eight screws removed in the disassembly procedure (Figure 3-9).

8. Complete the assembly portion of the Front Panel Controller Access Procedure.

### **3-96. A6A1 IEEE CONNECTOR PCB ACCESS PROCEDURE**

#### **3-97. Introduction**

3-98. The A6A1 IEEE Connector PCB is attached to the rear panel. The access procedure allows access to the printed circuit board for troubleshooting procedures. Figures 3-17 illustrates the disassembly and assembly procedures.

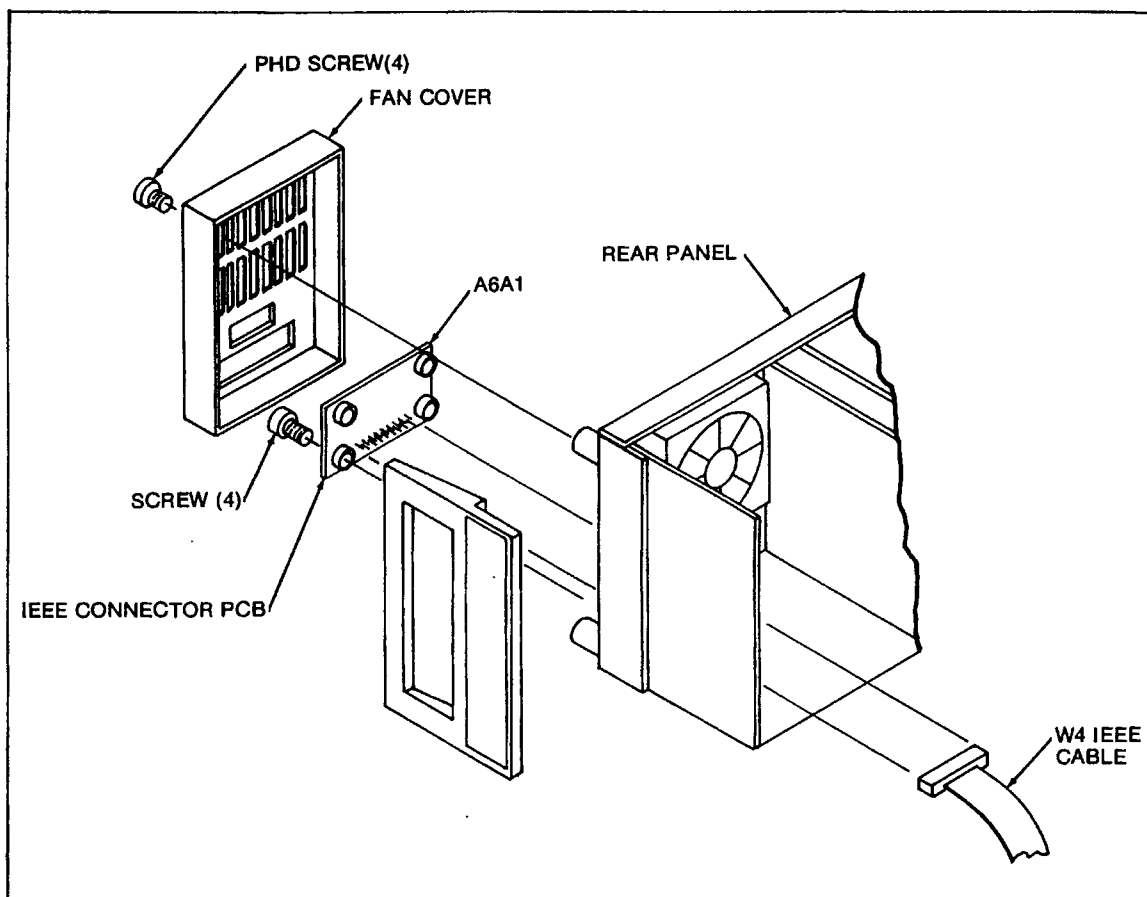

Figure 3-17. A6A1 IEEE Connector PCB Access

### 3-99. Disassembly Procedure

3-100. Complete the following procedure to gain access to the A6A1 printed circuit board.

1. Set the front panel POWER control to STBY. Set the rear panel MAIN POWER switch to OFF. Disconnect the instrument from line power.
2. Complete the disassembly portion of the Interior Access Procedure.
3. Swing the Synthesizer Module out using the following procedure:
  - a. Refer to Figure 3-8 and disconnect J3, J5, J6, J8 and J10.
  - b. Remove the four screws and washers (H1 and H2) and two screws (H3) shown in Figure 3-9.
4. Disconnect the IEEE cable from the IEEE connector PCB (Figures 3-9 and 3-17).

5. Remove the four Phillips head screws that hold the fan cover to the rear panel.

6. Remove the four screws that hold the A6A6 connector PCB to the rear panel.

### 3-101. Assembly Procedure

3-102. Complete the following procedure to assemble the instrument.

1. Align the screw holes and secure the IEEE PCB with the four screws previously removed (Figure 3-17).
2. Align the screw holes and secure the fan cover to the rear panel with the four Phillips head screws previously removed (Figure 3-17).
3. Connect the IEEE cable to the IEEE connector PCB.
4. Swing the Synthesizer Module back into place using the following procedure:

**CAUTION**

To avoid cable damage when swinging the synthesizer module back in place, make sure that the cables between the synthesizer plate and the delay line are in the positions shown in Figure 3-11.

- a. Remove the two screws (H3) from the Position B holes.
- b. Swing the Synthesizer Module completely into position; make sure that the semirigid coaxial cables between the Synthesizer Module and the Delay Line are in the positions shown in

Figure 3-11. This insures that these cables are not damaged by one of the screws in the Synthesizer Module cover or by cables being crossed over one another.

- c. Fasten the two screws (H3) into position A (Figure 3-9) and fasten the four washers and screws (H1 and H2) back in place.
  - d. Refer to Figure 3-8 and connect J3, J5, J6, J7, J8, J9, and J10.
5. Complete the assembly portion of the Interior Access Procedure.

## Section 4 Troubleshooting

### 4-1. INTRODUCTION

4-2. The information in this section provides general maintenance criteria for the 6070A/6071A Synthesized RF Signal Generator. Maintenance on the generator should be performed only by qualified technicians and personnel familiar with this type of equipment.

4-3. Maintenance adjustments of the 6070A/6071A can be separated into three categories: (1) calibration procedures, (2) manual non-routine adjustments, and (3) adjustments that require reprogramming of the Calibration EPROM. The calibration procedures are described in the Calibration Manual. The manual non-routine adjustments are described in Section 5 of this manual. The adjustments that require reprogramming of the Calibration EPROM require the use of a controller. Information on reprogramming of the Calibration EPROM is not given in this manual. Instead, the user is urged to return the generator to the nearest John Fluke Service Center when reprogramming of the Calibration EPROM is required. Refer to the Shipping and Service information that is given in Section 2 of the Calibration Manual.

### 4-4. ACCESS AND ASSEMBLY IDENTIFICATION

4-5. Access to the major assemblies is described in Section 3, Access Procedures. Section 3 also contains illustrations that identify the location of the major assemblies.

### 4-6. TROUBLESHOOTING

4-7. Section 4 restricts the discussion of the RF generator troubleshooting to suggestions of techniques for pinpointing trouble to a particular assembly. Once the faulty component is located, normal troubleshooting procedures are required. The following paragraphs suggest a few possible locations and causes of various symptoms.

### WARNING

**HIGH VOLTAGES ARE EXPOSED WHEN PERFORMING MAINTENANCE PROCEDURES ON AND NEAR THE POWER SUPPLY. OBSERVE ALL APPLICABLE SAFETY PRECAUTIONS IF LINE POWER IS CONNECTED TO THE INSTRUMENT.**

### CAUTION

**To prevent component damage, observe static awareness precautions. Refer to the yellow insert sheet.**

### 4-8. Error Codes (Self Check) at Power-On

4-9. At power-on the instrument model number (6070A or 6071A) appears in the FREQUENCY display, and the self test error code (0001, 0002, etc) appears in AMPLITUDE DISPLAY. The self test error codes are additive. For example, if the instrument failed the ROM test, the scratch pad memory RAM test, and the angle modulation test, the AMPLITUDE display would be 0205 as shown below:

ROM test failed	=0001
Scratch pad memory RAM test failed	=0004
Angle Modulation test failed	=0200
	—
AMPLITUDE display	=0205

4-10. The following table lists the Error Codes, Probable Cause, and Probable Fault Location for each error code.

### 4-11. UNCAL Annunciator Error Codes

4-12. Tables 4-2 and 4-3 list only the UNCAL annunciator error codes that indicate a hardware

6070A/6071A

malfunction. The tables list the error code, probable cause, and probable fault location to correct the indicated malfunction. Note that most UNCAL annunciator error codes indicate an incorrect signal output for the instrument. Refer to Section 5E of the 6070A/6071A Operator Manual for a complete listing and description of the displayed uncalibrated (UNCAL) error codes.

**4-13. Front Panel Connectors**

4-14. Table 4-4 is a quick reference table listing the front

panel connectors, the connecting cable, and the associated printed circuit boards. Refer to the wiring diagram in the 6070A/6071A Schematic Manual.

**4-15. Rear Panel BNC Connectors**

4-16. Table 4-5 is a quick reference table listing the rear panel connectors with associated connecting cable and printed circuit boards. Also refer to the wiring diagram in the 6070A/6071A Schematic Manual.

**Table 4-1. Error Codes (Self Check) at Power-On**

SYMPTOM	PROBABLE CAUSE	PROBABLE FAULT LOCATION
0001	ROM test failed.	1. Fault in A2A1 Controller PCB (U7 through U10 and U12 through U15).
0002	Calibration EPROM test failed.	1. Fault in A2A1 Controller PCB (U11).
0004	Scratch Pad Memory RAM test failed.	1. Fault in A2A1 Controller PCB (U2 through U4).
0010	Nonvolatile Memory test failed.	1. Fault in A2A2 Nonvolatile PCB.
0020	Mod/Divider test failed.	1. Fault in A4A4 Modulator/Divider PCB. 2. Fault in A4A9 Heterodyne Converter PCB. 3. Fault in A4A8 Heterodyne Oscillator PCB.
0040	Delay Discriminator Not Read test failed.	1. Fault in A3A3 Delay Discriminator PCB.
0100	Amplitude Modulation test failed.	
0400	Control Cable Continuity test error.	1. Faulty control cables to: A3A8 Synthesizer PCB A3A4 N/1 PCB. A4A4 Modulation Divider
1000	Frequency Doubler test failed.	1. Fault in A4A6 Output Amplifier PCB.
2000	Power-on Template recall failure.	1. Fault in A2A1 Controller PCB (U2 thru U4). 2. Fault in A2A1 Controller PCB (U7 thru U10, U12 thru U15). 3. Fault in A2A2 Non-volatile Memory PCB.
4000	Sub-Synthesizer.	1. Fault in A3A7 Sub-Synthesizer PCB.
10000	IEEE-488 Interface test failed.	1. Fault in controller interface on A2A1 Controller PCB.

Table 4-2. Modulation Display UNCAL Errors Codes

SYMPTOM	PROBABLE CAUSE	PROBABLE FAULT LOCATION
040 in MODULATION display	Error in discriminator loop.	1. The DIUNL signal path (cable W3) between A2A1 Controller and Synthesizer Module. 2. Fault in A2A1 Controller PCB.

Table 4-3. Frequency Display UNCAL Error Codes

SYMPTOM	PROBABLE CAUSE	PROBABLE FAULT LOCATION
010 in FREQUENCY display	Sub-synthesizer out of lock.	1. The SSULKL signal path (Cable W3) between A2A1 Controller and Synthesizer Module. 2. Fault in A2A1 Controller PCB. 3. Fault in A3A9 Synthesizer Distribution PCB. 4. Fault in A3A7 Sub-synthesizer PCB.
020 in FREQUENCY display	Delay Discriminator Fault.	1. The DDNRL signal path (Cable W3) between A2A1 Controller and Synthesizer Module. 2. Fault in A2A1 Controller PCB. 3. Fault in A3A9 Synthesizer Distribution PCB. 4. Fault in A3A3 Delay Discriminator PCB.
040 in FREQUENCY display	Main Loop out of lock.	1. The RPD signal path (Cable W3) between A2A1 Controller and Synthesizer Module. 2. Fault in A2A1 Controller PCB. 3. Fault in A3A9 Synthesizer Distribution PCB. 4. Fault in A3A1 Phase Detector PCB. 5. Any A3 Synthesizer Assembly PCB.

Table 4-4. Index of Front Panel Connectors

CONNECTOR	CONNECTING CABLE	PRINTED CIRCUIT BOARDS
MOD IN	Cable W10 between A1A1 Front Panel PCB (E1, E2) and Output Module J12 (A4A10J12).	A1A1 Front Panel. A4A10 Modulation Distribution.
MOD OUT (20 kHz 200 kHz)	Cable W11 between A1A1 Front Panel PCB (E2, E4) and Cable W53. Cable W52 to Output Module J14 (A4A2J14).	A1A1 Front Panel. A4A2 Modulation Oscillator.
RF OUTPUT	Cable W50 between A1A3 Output Connector and Output Module J3 (A4A4J3).	A4A5 Reverse Power Protect. A4A3 Attenuator. A4A7 Output Amplifier or A4A6 X2 Output Amplifier.
SWP OUT	Connector Mounted on the A1A1 Front Panel Assembly	A1A1 Front Panel.

Table 4-5. Index of Rear Panel BNC Connectors

BNC CONNECTOR	CONNECTING CABLE	CIRCUIT BOARDS
AUX OUTPUT (Option -831)	Cable W26 between rear panel BNC and Output Module J6 (A4A7J6).	A4A7 Output Amplifier.
MOD IN	Cable W25 between rear panel BNC and Output Module J11 (A4A10J11).	A4A10 Modulation Distribution.
PEN LIFT and OUT VALID	Cable W24 between rear panel BNC and Output Module J8 (A4A10J8).	A4A10 Modulation Distribution.
REF IN (External Timebase Ref Signal)	Cable W20 between rear panel BNC and Synthesizer Module J6 (A3A2J6).	A3A2 10 MHz Reference.
REF OUT (10 MHz Signal)	Cable W21 between rear panel BNC and Synthesizer Module J7 (A3A2J7).	A3A2 10 MHz Reference.
RF OUT (Option -830)	Cable W51 between A6A5 Rear Output Connector and Output Module J3 (A4A5J3).	A4A5 Reverse Power Protect. A4A3 Attenuator. A4A7 Output Amplifier or A4A6 X2 Output Amplifier.

#### 4-17. Printed Circuit Board Adjustable Components and Controls

4-18. Table 4-6 lists the printed circuit board adjustable components and controls. Every printed circuit board in the 6070A/6071A is listed. The REFERENCE column in the table sorts the adjustable components and controls into four categories; those adjustable components and controls that can be repaired, replaced, or adjusted using the routine adjustment procedures (6070A/6071A Calibration Manual); those adjustable components and controls that can be repaired, replaced, or adjusted using the non-routine adjustment procedures provided in Section 5 of this manual; those adjustable components and controls that cannot be repaired, replaced, or adjusted without having to reprogram the Calibration EPROM, and those adjustable components and controls that are factory adjustments. The adjustments that require reprogramming the Calibration EPROM require the use of a controller. Do not touch these components unless your facility is capable of reprogramming the Calibration EPROM. Do not touch components that require factory adjustment.

#### 4-19. Printed Circuit Board Switches

4-20. Table 4-7 contains a list of switches that are located on the 6070A/6071A printed circuit boards.

#### 4-21. A3A3 Discriminator PCB, Replacement Parts, and EPROM Calibration Information

4-22. If the following adjustment controls are disturbed, a major recalibration of the EPROM will be required. The controls are: R24, R48, R50, and R110.

4-23. Replacement of any part listed in the following table will require resetting the subject controls and subsequent recalibration of the Calibration EPROM. If any part(s) in Table 4-8 is (are) replaced, and consequently the subject controls need adjusting, the user is urged to return the signal generator to the nearest John Fluke Service Center.

#### 4-24. A3A5, A3A10 VCO Resonator PCB

4-25. The A3A5 VCO and the A3A10 VCO operate as a matched pair set, and they are closely associated with the Synthesizer Plate/EPROM calibration. Consequently, if repair or service is required, the user is urged to return the signal generator to the nearest John Fluke Service Center.

#### 4-26. A4A3 Attenuator PCB, Replaceable Parts and EPROM Calibration Information

4-27. Replacing of relays K1 through K6 and resistors R22 through R39 requires reprogramming the level correction portion of the Calibration EPROM. If these components are replaced, the user is urged to return the signal generator to the nearest John Fluke Service Center.



Table 4-6. Printed Circuit Board Adjustment Controls

PRINTED CIRCUIT BOARD	CONTROL	FUNCTION	REFERENCE
A1A1, A1A2 Front Panel PCB	R30	1 (MOD OUT)	Front Panel Control.
A2A1 Controller PCB	No Adjustments		
A2A2 Non-Volatile Memory PCB	No Adjustments		
A3A1 Phase Detector PCB	R2 Voltage	Equilization Network Offset Compensation.	Factory Adjust Only.
	R4	High-rate, FM/ϕM Deviation.	See Calibration Manual for Adjustment Procedure.
	R5	High-rate, FM/ϕM Balance.	See Calibration Manual for Adjustment Procedure.
	R10	Low-rate, FM Deviation.	See Calibration Manual for Adjustment Procedure.
	R10	Low-rate, FM Deviation.	See Calibration Manual for Adjustment Procedure.
	R12	Low-rate, ϕM Deviation.	See Calibration Manual for Adjustment Procedure.
	R25	Low noise (discriminator) Loop Bandwidth Adjust.	Requires EPROM Reprogrammed.
	R35	Integrator Offset Adjust.	See Section 5 for non-routine adjustment procedure.
	R37	VCO Control Voltage (only with SW1 in Test).	Factory Adjust Only.
	L4, L5	Low Pass Filter Adjust.	Factory Adjust Only.
A3A2 10 MHz Reference PCB	C9	Crystal Oscillator Frequency.	See Calibration Manual for Adjustment Procedure.
A3A3 Discriminator PCB	R24	Leveling Loop Level Adjustment.	Requires EPROM Reprogrammed.
	R45	Phase Shifter Zero Adjustment.	See Section 5 for non-routine adjustment procedure.
	R48, R50	Varactor Tuned Filter Shape Factor Adjustment.	Required EPROM Reprogrammed.
	R53	Not HI DEV Mode: Low-Rate, 99.9 kHz Deviation.	See Calibration Manual for Adjustment Procedure.
	R67	Not HI DEV Mode: Low-Rate, 199 kHz Deviation.	See Calibration Manual for Adjustment Procedure.

Table 4-8. Printed Circuit Board Adjustment Control (cont)

PRINTED CIRCUIT BOARD	CONTROL	FUNCTION	REFERENCE
	R86	Discriminator Zero Adjustment.	See Section 5 for non-routine Adjustment Procedure.
	R103	HI DEV Mode: High Rate Deviation.	See Calibration Manual for Adjustment Procedure.
	R110	HI DEV Mode: Loop Bandwidth Adjustment.	Requires EPROM Reprogrammed.
	R146	FET Tracking Adjustment.	See Section 5 for non-routine Adjustment Procedure.
A3A4 N/1 Divider PCB	No adjustments		
A3A5, A3A10 VCO	No adjustments		
A3A6 SSB Mixer PCB	R30	Phase Detector Gain. Adjusted for FM flatness.	See Section 5 for non-routine Adjustment Procedure.
	R51	Lower Frequency Limit.	See Section 5 for non-routine Adjustment Procedure.
	R52	Upper Frequency Limit.	See Section 5 for non-routine Adjustment Procedure.
A3A7 Sub Synthesizer PCB	L5	VCO Frequency Adjust.	See Section 5 for non-routine Adjustment Procedure.
A3A8 Synthesizer Control Buffer PCB		No Adjustments.	
A3A9 Synthesizer Distribution PCB	C9	High Frequency Compensation.	See Section 5 for non-routine Adjustment Procedure.
	R8	KV DAC (U8) Offset Adjust.	See Section 5 for non-routine Adjustment Procedure
	R10	Overall Deviation Calibration.	See Calibration Manual.
A4A2 Modulation Oscillator PCB	R6	Mod Oscillator Level.	See Calibration Manual.
	R13	FET Bias Adjustment.	See Section 5 for non-routine Adjustment Procedure.
	R23	Offset Voltage Adjustment, U8.	See Section 5 for non-routine Adjustment Procedure.
	R27	Bias Current Compensation Adjust, U13.	See Section 5 for non-routine Adjustment Procedure.
A4A3 Attenuator PCB	No Adjustment Controls.		

Table 4-6. Printed Circuit Board Adjustment Control (cont)

PRINTED CIRCUIT BOARD	CONTROL	FUNCTION	REFERENCE
A4A4 Modulator Divider	R24	Modulator Gain Adjust, U18. Part of loop BW Adjustment.	Factory Adjust Only.
	R26	Modulator Gain Adjust, U10. Part of Loop BW Adjustment.	Factory Adjust Only.
	R28	Modulator Gain Adjust, U8. Part of Loop BW Adjustment.	Factory Adjust Only.
	R30	Modulator Gain Adjust, U12. Part of Loop BW Adjustment.	Factory Adjust Only.
	R32	Modulator Gain Adjust, U5. Part of Loop BW Adjustment.	Factory Adjust Only.
	R39	Modulator Gain Adjust, Q3. Part of Loop BW Adjustment.	Factory Adjust Only.
	R47	Modulator Gain Adjust, Q4. Part of Loop BW Adjustment.	Factory Adjust Only.
	R88	ALC Gain Adjust, U2.	Requires EPROM Reprogramming.
A4A5 Reverse Power Protect PCB	R7	RPP Trip Level.	See 607XA-890 Option In Calibration Manual.
A4A6 X2 Output Ampl PCB (6071A only)	C22	Select <5 MHz ALC Loop Bandwidth.	Requires EPROM Reprogramming.
	C23	Select <5 MHz ALC Loop Bandwidth.	Requires EPROM Reprogramming.
	R20	Adjust U2 Current Harmonics.	Requires EPROM Reprogramming.
	R29	>5 MHz Detector Offset.	See Calibration Manual for Adjustment Procedure.
	R35	>5 MHz, <5 MHz Detector Balance.	Requires EPROM Reprogramming.
	R37	<5 MHz Detector Offset.	See Calibration Manual for Adjustment Procedure.
	R53	U15 Input Offset Zero.	See Calibration Manual for Adjustment Procedure.
	R60	U16 Input Offset.	See Section 5 for non-routine Adjustment Procedure.
R75	U17 Input Offset.	See Section 5 for non-routine Adjustment Procedure.	

Table 4-6. Printed Circuit Board Adjustment Control (cont)

PRINTED CIRCUIT BOARD	CONTROL	FUNCTION	REFERENCE
A4A7 Output Ampl PCB (6070A only)	R89	Adjust U9 Current, Harmonics.	See Section 5 for non-routine Adjustment Procedure.
	R91	Subharmonic Adjust.	See Section 5 for non-routine Adjustment Procedure.
	C51	Select <5 MHz ALC Loop Bandwidth.	Requires EPROM Reprogramming.
	C52	Select <5 MHz ALC Loop Bandwidth.	Requires EPROM Reprogramming.
	R4	>5 MHz Detector Offset.	See Calibration Manual for Adjustment Procedure.
	R6	<5 MHz Detector Offset.	See Calibration Manual for Adjustment Procedure.
	R9	U4 Input Offset Zero.	See Calibration Manual for Adjustment Procedure.
	R24	U5 Input Offset.	See Section 5 for non-routine Adjustment Procedure.
	R25	U4 Input Offset.	See Section 5 for non-routine Adjustment Procedure.
	R36	U7 Input Offset.	See Section 5 for non-routine Adjustment Procedure.
	R48	>5 MHz, <5 MHz Detector Balance.	Requires EPROM Reprogramming.
	R56	Adjust U2 Current, Harmonics.	Requires EPROM Reprogramming.
	R58	Adjust U6 Current, Harmonics.	Requires EPROM Reprogramming.
	A4A8 Heterodyne Oscillator PCB	C21	RF Bypass Adjustment.
C64		RF Bypass Adjustment.	Factory Adjust Only.
L7		Phase-shift Adjustment.	Factory Adjust Only.
L8		Phase-shift Adjustment.	Factory Adjust Only.
R8		Temperature Compensation Null	Factory Adjust Only.
R11		Frequency Gain Adjustment.	Factory Adjust Only.

Table 4-6. Printed Circuit Board Adjustment Control (cont)

PRINTED CIRCUIT BOARD	CONTROL	FUNCTION	REFERENCE
A4A9 Heterodyne Converter PCB	R13	Temperature Compensation Gain Adjustment.	Factory Adjust Only.
	R18	Center Frequency Offset Adjustment.	Factory Adjust Only.
	R75	Loop Bandwidth Adjustment.	Factory Adjust Only.
	C11	Matching Capacitor, Q1, Q2.	See Section 5 for non-routine
	C15	Tuning Capacitor.	See Section 5 for non-routine Adjustment Procedure.
	R6	Gain Adjustment, Q1.	See Section 5 for non-routine Adjustment Procedure.
A4A10 Modulation Distribution PCB	R42	Gain Adjustment, Q2.	See Section 5 for non-routine Adjustment Procedure.
	C13	U26 High Frequency Response, Adjustment.	See Section 5 for non-routine
	R12	X6.25 (1.25 Scale factor) Gain Adjustment.	See Section 5 for non-routine Adjustment Procedure.
	R13	X4 (0.8 Scale factor) Gain Adjustment.	See Section 5 for non-routine Adjustment Procedure.
	R14	X5 (X1 Scale Factor) Gain Adjustment.	See Section 5 for non-routine Adjustment Procedure.
	R22	AM Calibration.	See Calibration Manual for Adjustment Procedure.
	R31	DCFM Deviation Adjustment.	See Calibration Manual for Adjustment Procedure.
	R33	DCFM Mode: High-Rate, 500 kHz Deviation.	See Calibration Manual for Adjustment Procedure.
	R38	Level DAC.	See Section 5 for non-routine Adjustment Procedure.
	R41	FM DAC Offset Adjustment.	See Section 5 for non-routine Adjustment Procedure.
	R43	Offset Voltage Adjustment, U19 (Equalization Network).	See Section 5 for non-routine Adjustment Procedure.
	R44	+/- Gain Balance, U23.	See Section 5 for non-routine Adjustment Procedure.
R46	-1 Gain Offset Voltage Adjust, U23.	See Section 5 for non-routine Adjustment Procedure.	

Table 4-6. Printed Circuit Board Adjustment Control (cont)

PRINTED CIRCUIT BOARD	CONTROL	FUNCTION	REFERENCE
	R48	DCFM Mode: Low-Rate Deviation Adjustment.	See Section 5 for non-routine Adjustment Procedure.
	R50	1/N DAC Offset Voltage Adjustment, U19.	See Section 5 for non-routine Adjustment Procedure.
	R54	DCFM Buffer Offset Voltage Adjustment, U18.	See Section 5 for non-routine Adjustment Procedure.
	R55	Output Level Calibration.	See Section 5 for non-routine Adjustment Procedure.
	R58	AM DAC Offset Voltage Adjustment, U28.	See Section 5 for non-routine Adjustment Procedure.
	R61	+1 Gain Offset Voltage Adjustment, U23.	See Section 5 for non-routine Adjustment Procedure.
A5A1 Power Supply PCB	No adjustments.		
A5A2 Power Supply Regulator	R1	Frequency Adjustment.	See Calibration Manual for Adjustment Procedure.
	R7	6V Adjust.	See Calibration Manual for Adjustment Procedure.
A5A3 Aux Transformer	No adjustments.		
A5A4 Input Rectifier PCB	No adjustments.		
A5A5 Switching Transistors	No adjustments.		
A5A6 Power Supply Capacitor	No adjustments.		
A6A1 IEEE Connector PCB	No adjustments.		
A6A2 Series Pass Motherboard PCB	No adjustments.		
A6A3 +5 Volt Series-Pass Regulator	No adjustments.		
A6A4 +12V, -12V, +24V Series-Pass Regulator PCB	R5	Voltage Adjust (All Power Supply Voltages).	See Calibration Manual for Adjustment Procedure.
607XA-130 (Option)	COARSE	Coarse Frequency Adjustment.	See Calibration Manual for Adjustment Procedure.
	FINE	Fine Frequency Adjustment.	See Calibration Manual for Adjustment Procedure.

Table 4-7. Printed Circuit Board Switches

ASSEMBLY	SWITCH	FUNCTION
A2A1 Controller	U30	#1 Used to test microprocessor U22 and clock generator U25. #2 Self test bypass switch. #3 Should normally be open (off). #4 Should normally be open (off).
A2A2 Non-Volatile Memory PCB	S1	Battery Standby Switch: Open, Battery out of Circuit (for service and transport); Closed, Battery in Circuit.
A3A1 Phase Detector PCB	SW1	Test position of switch opens main loop and allows manual frequency adjustment via R37.
A3A2 10-MHz Reference PCB	S1	Reference Frequency Selector. Selects internal oscillator or Option -130. If the Synthesizer Module is swung out when serving an instrument with a -130 Option, the 10 MHz reference is disconnected. This switch provides a convenient method of operating the module temporarily on the internal oscillator.
A3A4 N/1	SW1	Input signal Selector Test Switch. Allows the signal from the main loop VCO to be routed directly to the N/1 Divider, thus bypassing the A3A6 SSB Mixer and the A3A7 Sub-Synthesizer modules. This is accomplished by disconnecting cable W36 from J2 of A3A6 and connecting it to J2 of A3A4.

Table 4-8. Replaceable Parts Requiring EPROM Recallibration (A3A3 PCB)

REFERENCE DESIGNATION FOR REPLACEMENT PARTS			
C11	C80	L1	R151
C13	C82	through	T1
C21	CR6	L4	T2
C22	through	L6	T3
C23	CR11	through	U5
C24	CR14	L8	U6
C25	CR15	L18	U23
C53	CR18	through	W2
C63	through	L20	W3
C66	CR21	R6	Delay
C68	CR24	R23	Cable
C70	through	R30	
C71	CR27	R31	
C78		R46	
C79			

4-28. All other components are field replaceable. Careful disassembly and reassembly of this printed circuit board is necessary if calibration is to be maintained.

#### 4-29. A4A6 X2 Output Amplifier PCB Replaceable Parts and Procedure

4-30. There are several components, that if replaced, require reprogramming the level portion of the Calibration EPROM. If these components are replaced

the user is urged to return the generator to the nearest John Fluke Service Center. The components are: U9, U20, K3, K4, R43, R44, and R45.

4-31. Replacing any part listed in Table 4-9 requires performing the A4A6 X2 Output Amplifier Service Routine Adjustment first (column G), then performing the other indicated procedures listed in the table.

#### 4-32. A4A7 Output Amplifier PCB, Replaceable Parts and Procedure

4-33. Replacing any component below requires reprogramming the level correction portion of the Calibration EPROM. If these components are replaced, the user is urged to return the generator to the nearest John Fluke Service Center. The components are: U3, U6, K1, K2, R31, R32, and R33.

4-34. Replacement of any part listed in Table 4-10 requires performing the A4A7 Output Amplifier Service Routine Adjustment first (column F) then performing the other procedures indicated in the table.

#### 4-35. A4A8 Heterodyne Oscillator PCB, Replacement Parts and Factory Service Information

4-36. Replacement of any part listed in Table 4-11 will require factory calibration of the A4A8 Heterodyne Oscillator PCB. The user is urged to return the signal generator to the nearest John Fluke Service Center.

Table 4-9. Replaceable Parts and Procedures (A4A6 PCB)

PART REPLACED	PROCEDURES*							PART REPLACED	PROCEDURES*						
	A	B	C	D	E	F	G		A	B	C	D	E	F	G
BPF 1 through BPF 4		X		X	X		X	R29	X	X					X
C14				X	X		X	R35	X	X					X
C16				X	X		X	R36	X	X					X
C23**						X	X	R37	X	X					X
C33**						X	X	R40	X	X					X
C35						X	X	R42	X	X		X			X
C74						X	X	R52	X	X					X
C78						X	X	R53	X	X					X
C79						X	X	R59	X	X					X
C84	X	X					X	R60	X	X					X
C85	X	X					X	R61	X	X				X	X
C86	X	X					X	R62	X	X				X	X
CR6	X	X				X	X	R63	X	X				X	X
CR7	X	X				X	X	R64	X	X				X	X
CR8	X	X				X	X	R65	X	X				X	X
CR9	X	X				X	X	R66	X	X				X	X
CR10	X	X				X	X	R68	X	X					X
CR11	X	X				X	X	R69	X	X				X	X
CR20		X		X	X		X	R70	X	X				X	X
through CR35							X	R71	X	X				X	X
K1		X	X				X	R73	X	X				X	X
K2		X	X				X	R74	X	X				X	X
L6	X	X					X	R75	X	X				X	X
Q1				X	X		X	R84	X	X					X
Q2				X	X		X	R89		X		X	X		X
Q4	X	X					X	T1				X			X
Q5	X	X					X	U1		X		X			X
Q10						X	X	U2	X	X	X	X	X		X
Q11						X	X	U3		X		X	X		X
R20	X	X	X	X			X	U6		X	X	X	X		X
R21	X	X	X	X			X	U7		X		X			X
R28	X	X					X	U15	X	X					X
								U16	X	X					X
								U17	X	X					X

\*Procedures: A. RF OUTPUT LEVEL CHECK in the Calibration Manual.  
 B. LEVEL FLATNESS CHECK procedure in Section 5  
 C. GENERATOR SOURCE IMPEDANCE (SWR) CHECK in the Calibration Manual.  
 D. RF HARMONIC CHECK in the Calibration Manual.  
 E. X2 OUTPUT AMPLIFIER SUBHARMONIC ADJUSTMENT PROCEDURE procedure in Section 5.  
 F. AM CHECK in the Calibration Manual.  
 G. A4A6 X2 OUTPUT AMPL SERVICE ROUTINE ADJUSTMENT in Section 5

\*\*C23, C33: Factory selected value capacitors: replace only with exact replacement value capacitors.



Table 4-10. Replaceable Parts and Procedures (A4A7 PCB)

PART REPLACED	PROCEDURES*						PART REPLACED	PROCEDURES*					
	A	B	C	D	E	F		A	B	C	D	E	F
C11	X	X			X	X	R17	X	X			X	X
C12	X	X				X	R18	X	X			X	X
C15	X	X					R19	X	X			X	X
C23					X	X	R20	X	X			X	X
C24					X	X	R23	X	X				X
C25					X	X	R24	X	X				X
C35					X	X	R25	X	X				X
C52**					X	X	R26	X	X			X	X
CR1	X	X			X	X	R27	X	X			X	X
CR2	X	X			X	X	R36	X	X			X	X
CR3	X	X			X	X	R37	X	X			X	X
CR4	X	X			X	X	R42	X	X			X	X
CR5	X	X			X	X	R44	X	X			X	X
CR6	X	X			X	X	R46	X	X			X	X
L6	X	X				X	R47	X	X				X
Q1	X	X				X	R48	X	X				X
Q2	X	X					R53	X	X			X	X
Q4					X	X	R55	X	X	X	X		X
Q5					X	X	R56	X	X	X	X		X
R2	X	X				X	R57		X		X		X
R4	X	X				X	R58		X		X		X
R5	X	X				X	U1		X		X		X
R6	X	X				X	U2	X	X	X	X		X
R8	X	X				X	U4	X	X				X
R9	X	X				X	U5	X	X				X
R11	X	X				X	U7	X	X				X

\*Procedures: A. RF OUTPUT LEVEL CHECK in the Calibration Manual.  
B. LEVEL FLATNESS CHECK procedure in Section 5.  
C. GENERATOR SOURCE IMPEDANCE (SWR) CHECK in the Calibration Manual.  
D. RF HARMONIC CHECK in the Calibration Manual.  
E. AM CHECK in the Calibration Manual.  
F. A4A7 OUTPUT AMPLIFIER SERVICE ROUTINE ADJUSTMENT in Section 5.

\*\*C51, C52: Factory selected value capacitors; replace only with exact replacement value capacitors.

Table 4-11. Replacement Parts Requiring Factory Calibration (A4A8 PCB)

C20	C64	L7	RT1 (thermistor)
C21	CR2	L8	U12 (SAW Delay Line)
C49	CR3	Q3	

Calibration EPROM. If these parts are replaced, the user is urged to return the signal generator to the nearest John Fluke Service Center. The components that require EPROM recalibration are: C12, C18, CR1 through CR4, CR11 through CR14, and K1.

#### 4-37. 607XA-870 Reverse Power Protection Option (RPP)

4-38. Replacing some of the parts requires reprogramming the level correction portion of the

4-39. All other parts are field replaceable. When any component is replaced the 607XA-870 Reverse Power Protection Option Adjustment procedure should be performed. The procedure is located in Section 7C of the 6070A/6071A Calibration Manual.

0

0

0

0